

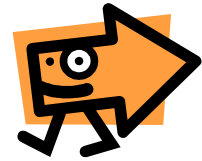

User manual

Quick start







www.ira.com

[Required configuration : Page 4](#)

[Installing : Page 5](#)

[Version : Page 6](#)

[Differences V6 / V7 : Page 7](#)

[New features V7 : Page 9](#)

[Creating automation application : Page 12](#)

[Running an application on a PC : Page 18](#)

[Adding a supervision object : Page 19](#)

[Running an application on a PLC : Page 21](#)

[Opening an example of 3D OP simulation : Page 22](#)

[Creating a 3D OP simulation application : Page 23](#)

[To find information : Page 31](#)

[To contact IRAI : Page 32](#)

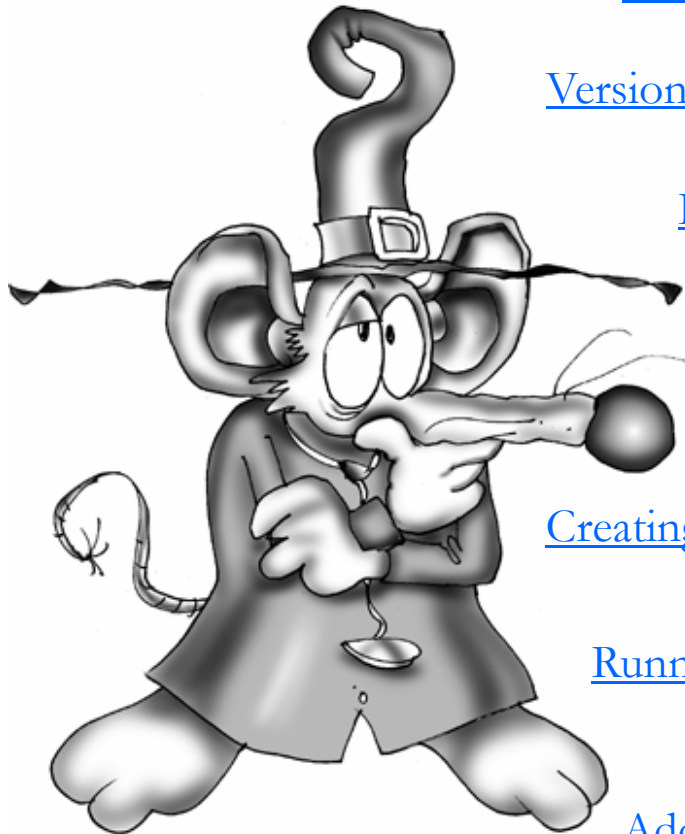



7

www.iri.com

Required configuration



95
98
ME
NT4
2000
XP

32MO RAM

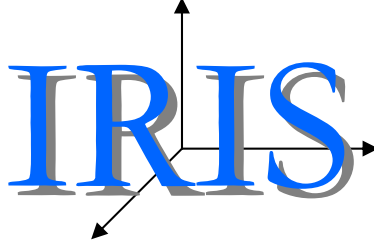

95
98
ME
~~NT4~~
2000
XP

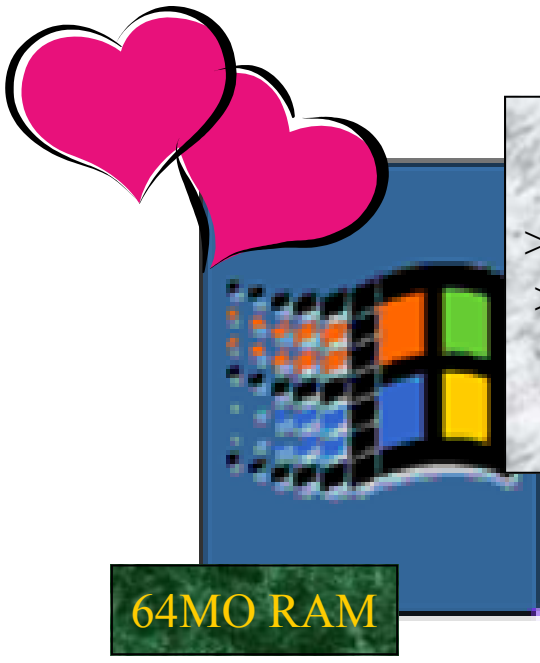

>=98 SE
>=2000

64MO RAM



7

www.irai.com

Installing

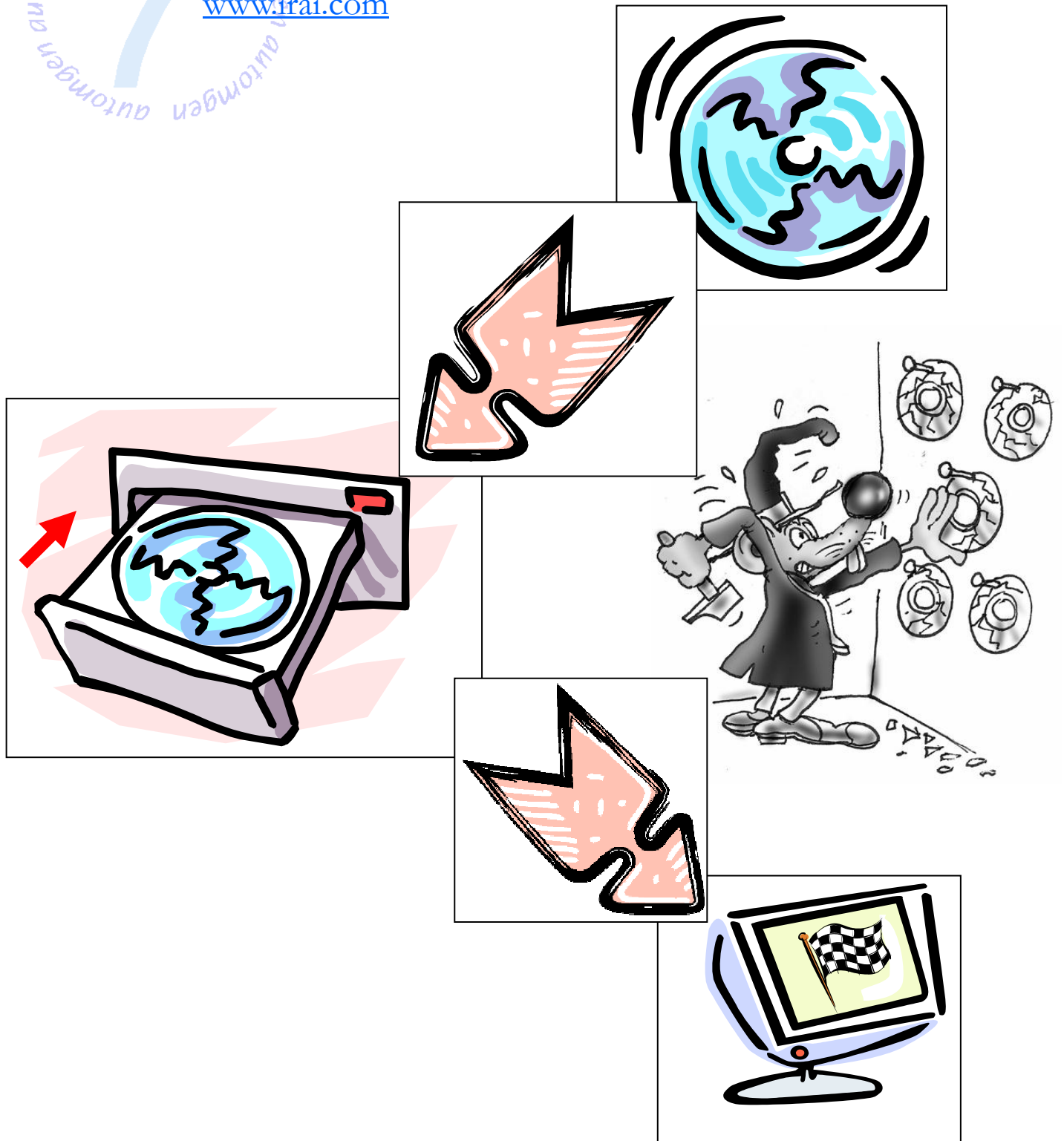

If the installation procedure is not launched automatically, launch the executable « Setup.exe » located in the root on the CD-ROM.



7

www.ira.com

Version

02 / 15 / 2002

First commercial version of
AUTOMGEN⁷

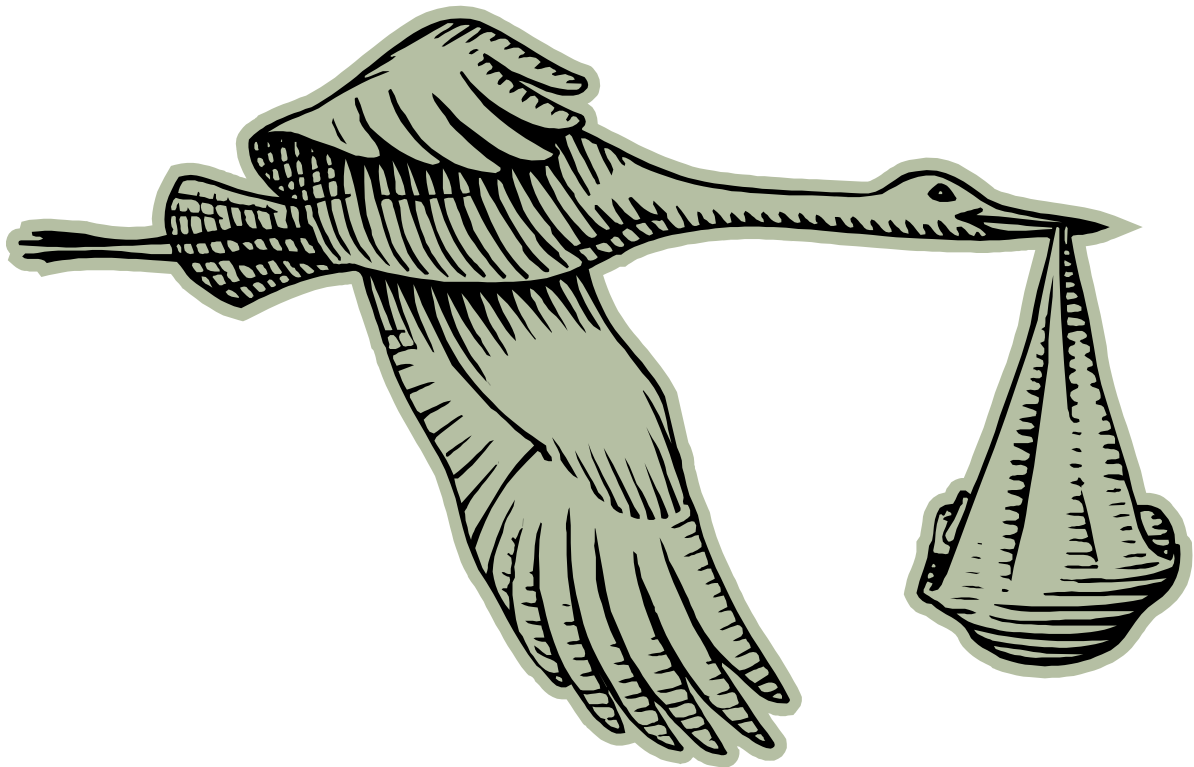

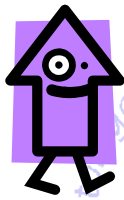

7
www.ira.com

Differences V6 / V7 (1/2)

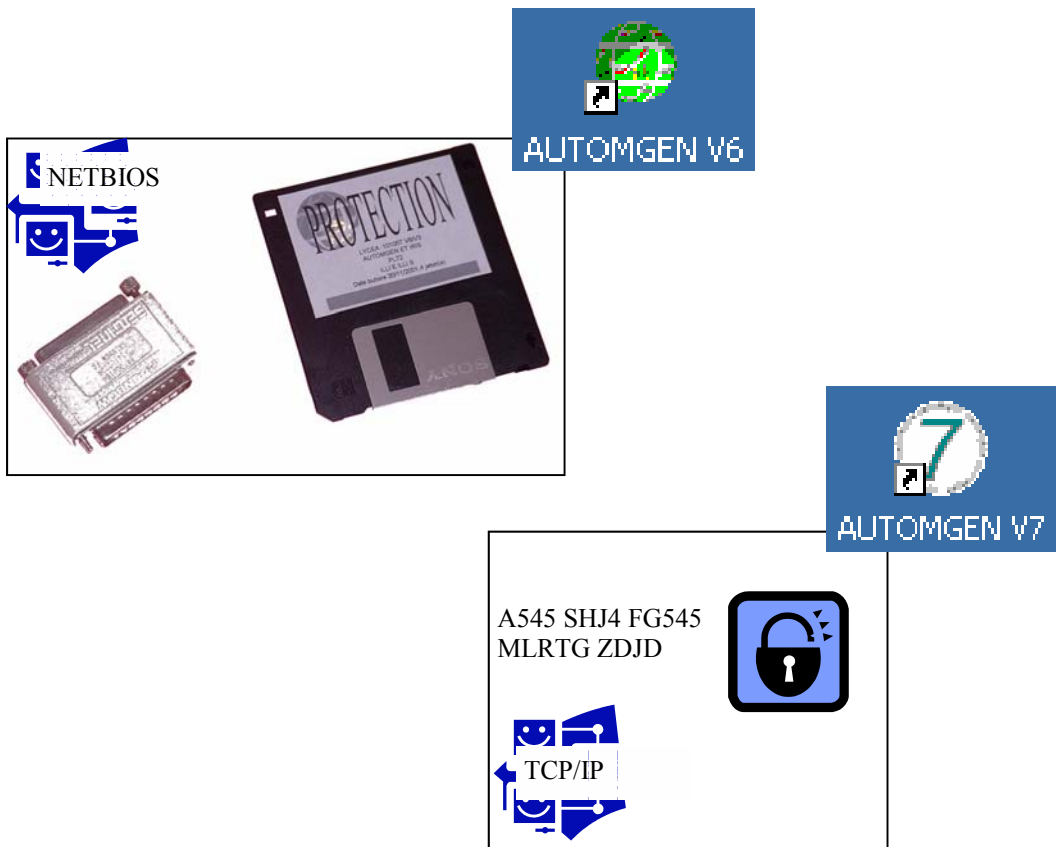
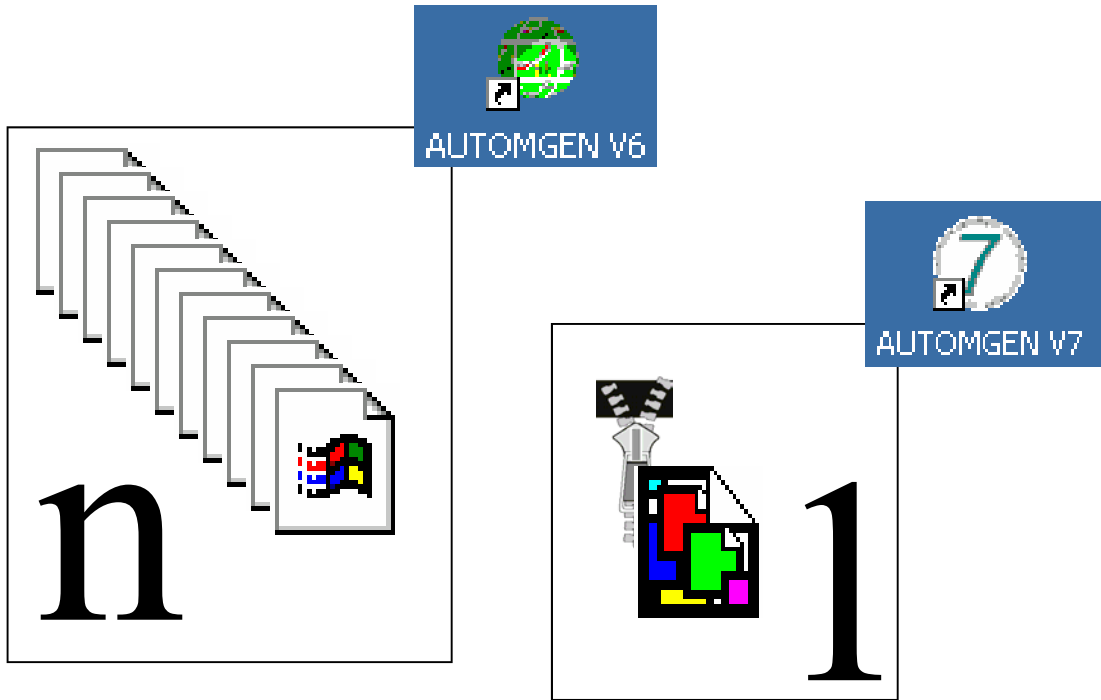
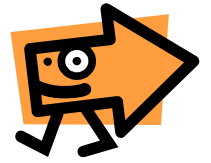

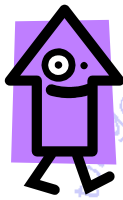

www.irai.com

Differences V6 / V7 (2/2)

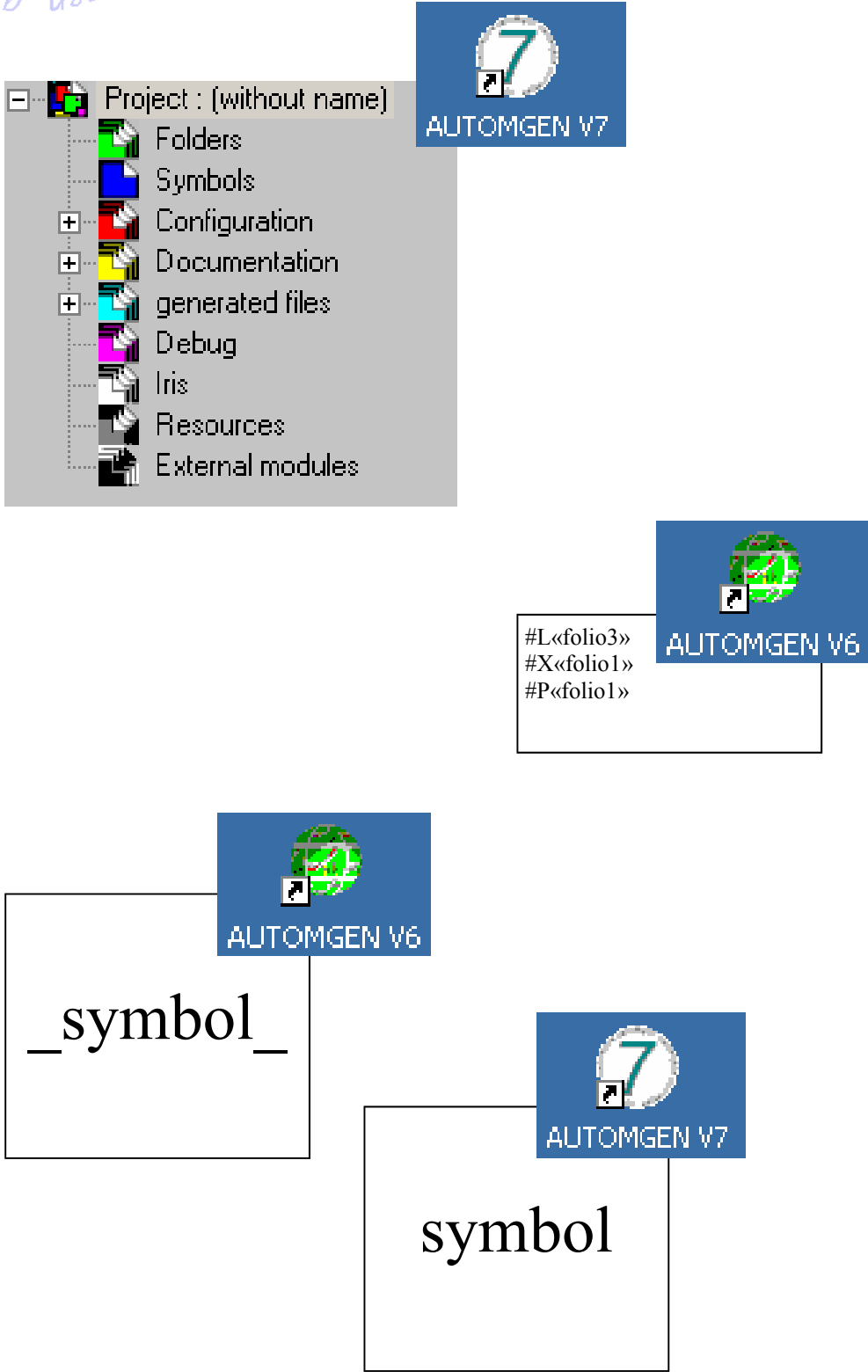
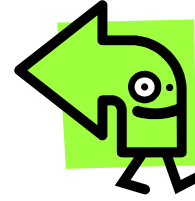

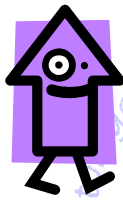

New features V7 (1/3)

www.irai.com

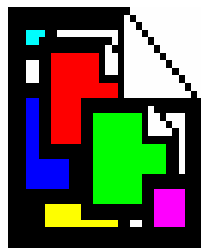
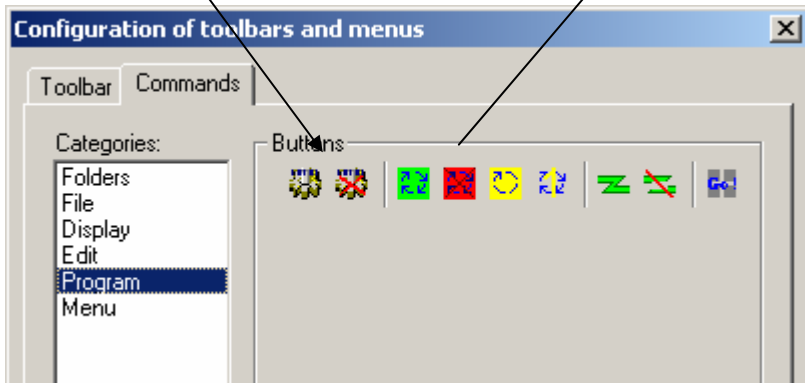
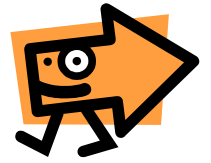

EXE

IRIS

 Add an IRIS 3D console

SOLIWORKS
SOLIDCONCEPTER
3DSTUDIO
FICHIERS VRML

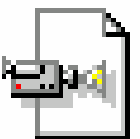
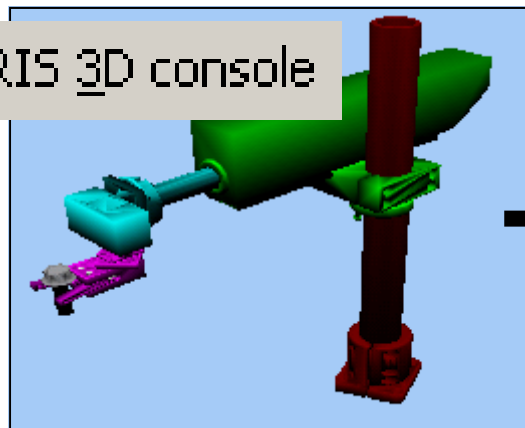



New features V7 (2/3)

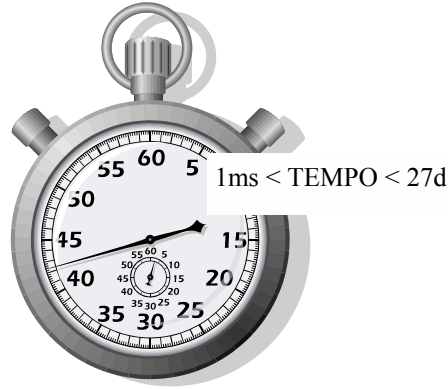
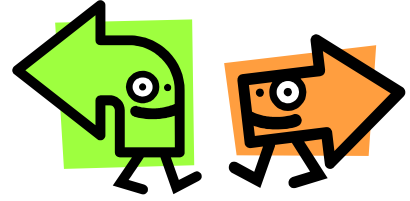

```
+ decy. | (m200>4+m200<
```

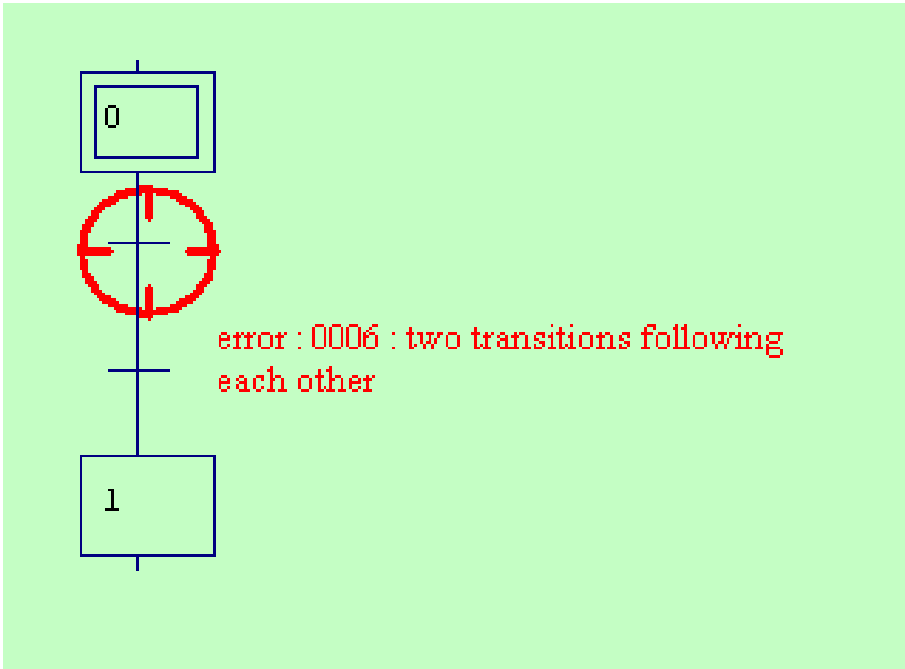
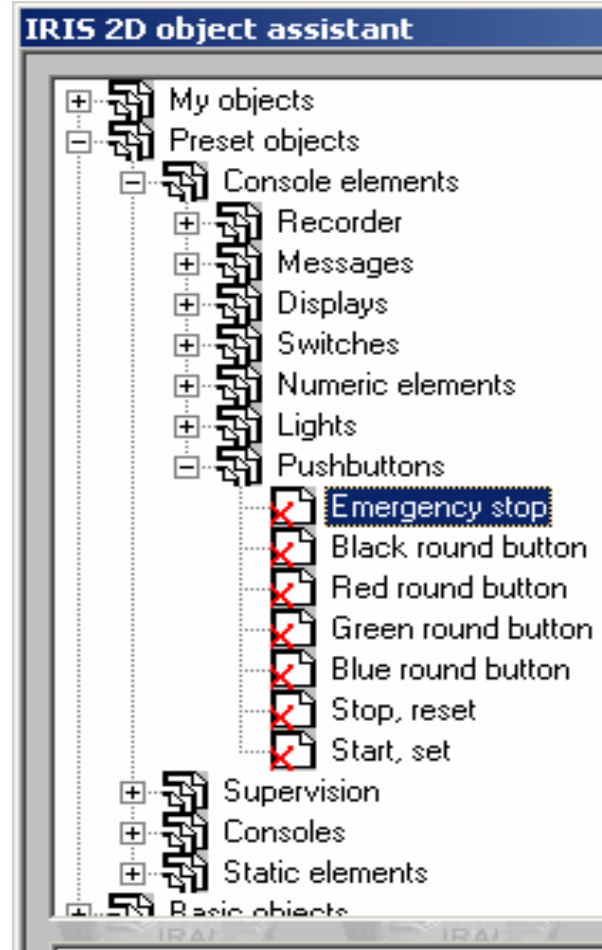

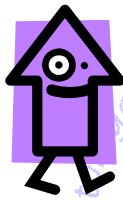

New features V7 (3/3)

www.traf.com

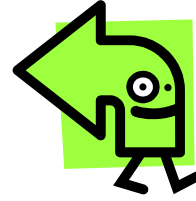

Project : (without name)

- [-] Folders
 - Folder 1
- [-] Symbols
- [-] Configuration
 - [-] Post-processors
 - [+] Exécuteur PC
 - [+] PI7 (Tsx 37 & Tsx 57)
 - [+] PL72
 - [-] STEP7 (S7200)
 - System
 - Variable correspondence
 - Begin machine code

Elements	Values
[-] Hardware setup	
..... PLC model	1720
..... Extension #1 code (0 if none)	0
..... Extension #2 code (0 if none)	0
..... Extension #3 code (0 if none)	0
..... I0,0 input	NORMAL
..... O0,0 output	NORMAL
..... I0,24 input	NORMAL
..... I0,25 input	NORMAL
[+] Software setup	
[+] Constant words	
[+] Text FB	
[+] Code builder options (learning, modify)	

Connection options

Connect and download



Do not use this dialogue box any longer, always use the option selected



Communication parameters

Set as default

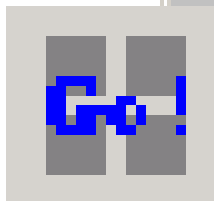

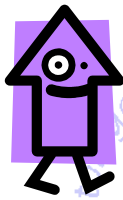

Creating automation application 1/6

www.ira.com

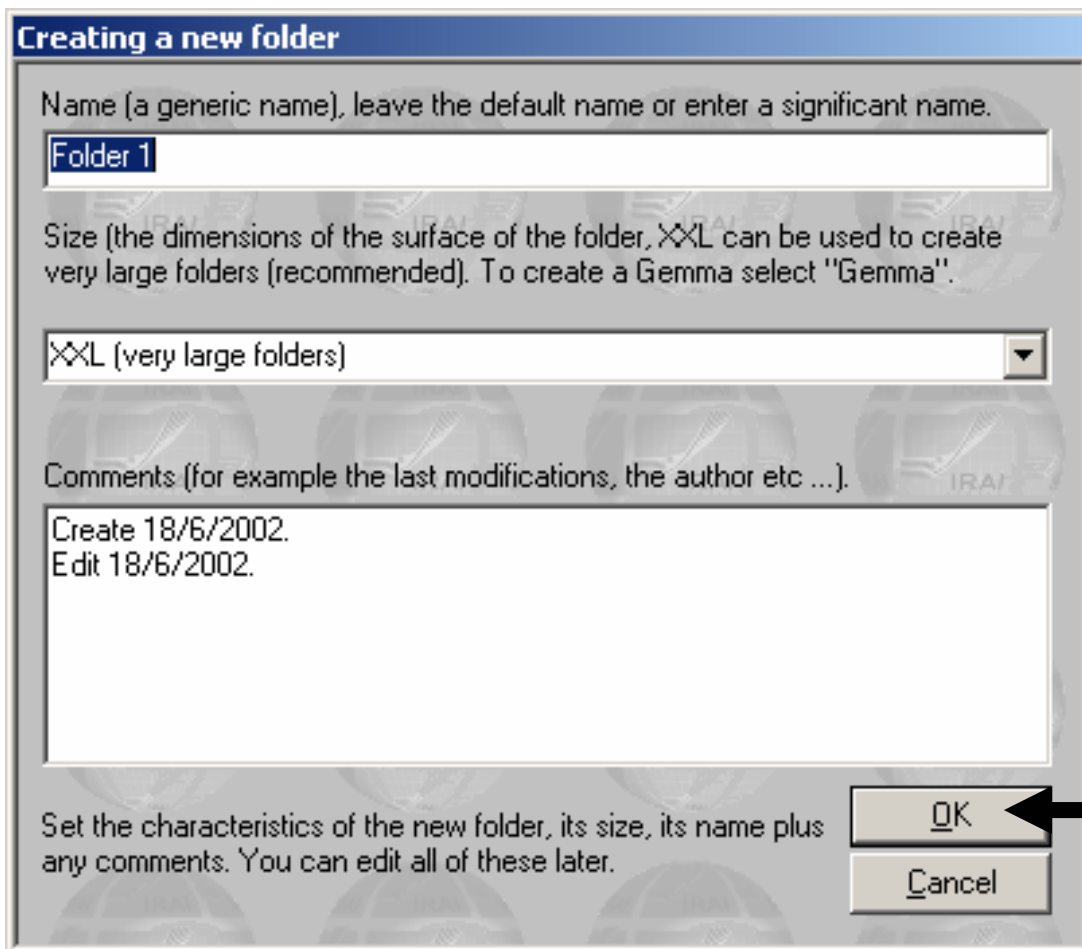
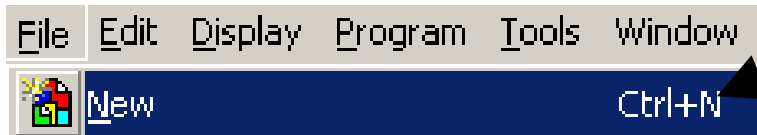
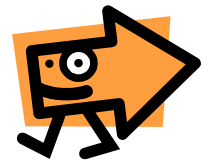



Creating automation application 2/6

www.trafai.com

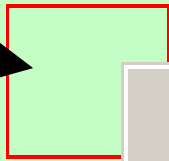
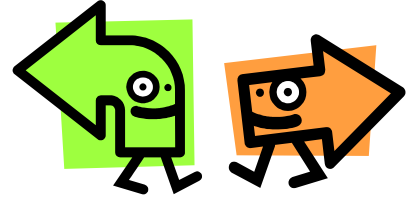

	Initial step
	Normal step
	transition
	link
	assistant
Plus ... ▶	
Edit ... ▶	



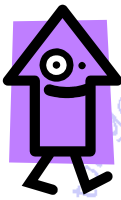

Creating automation application 3/6

www.ira1.com

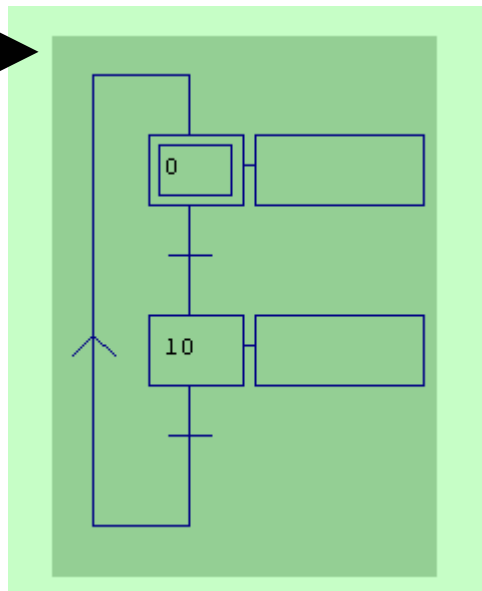
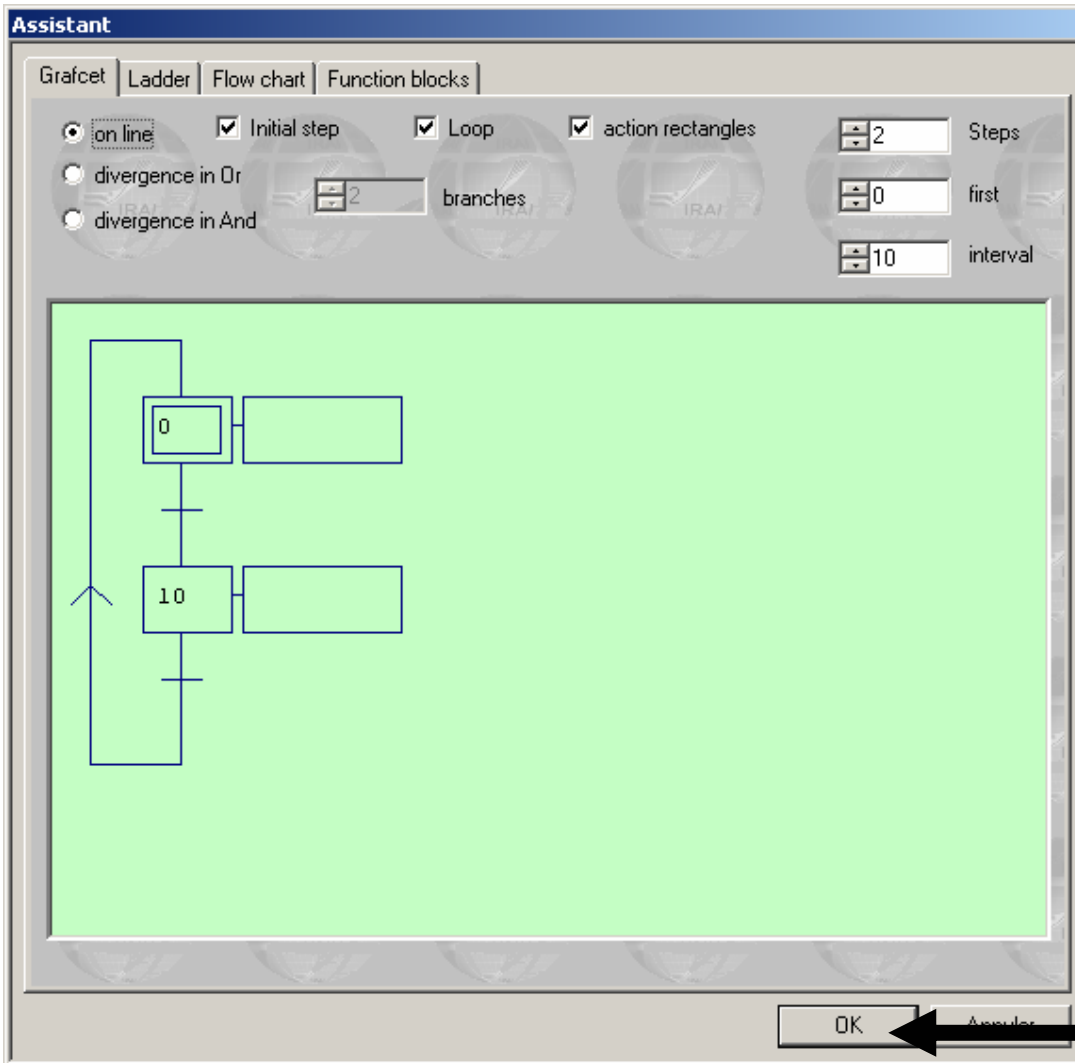
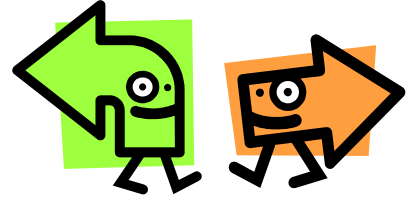



Creating automation application 4/6

www.ira.com

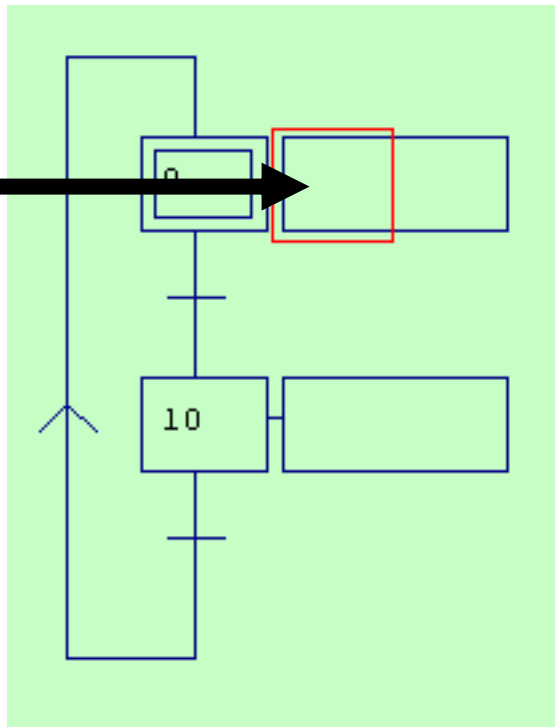
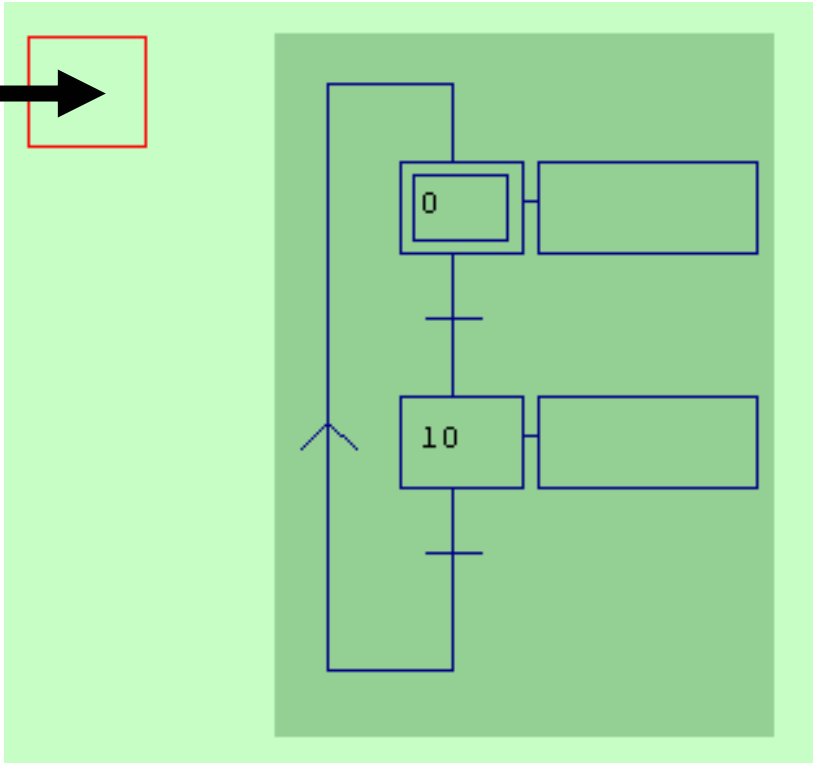
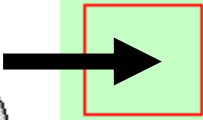
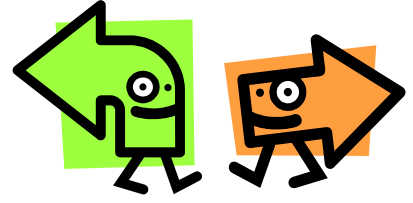



Creating automation application 5/6

www.irai.com

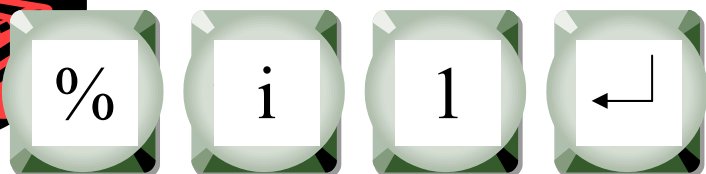
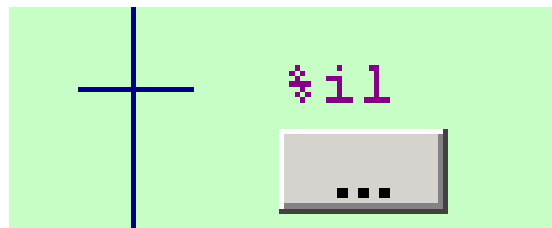
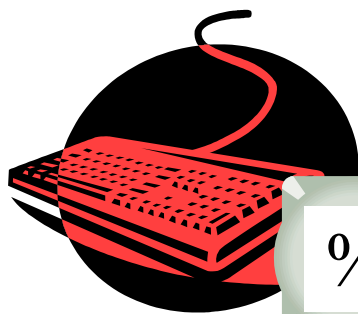
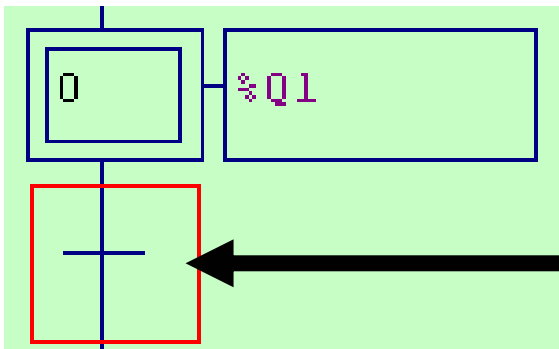
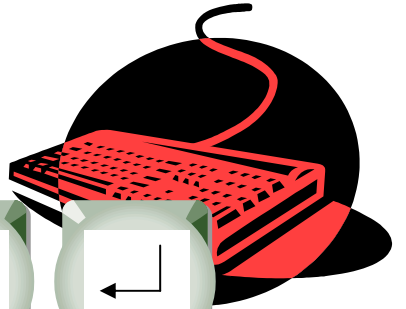
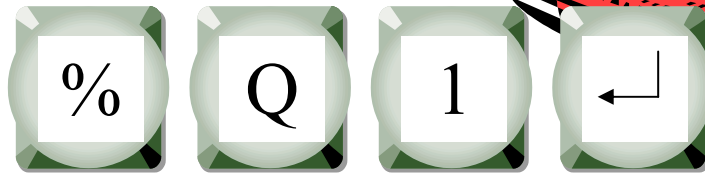
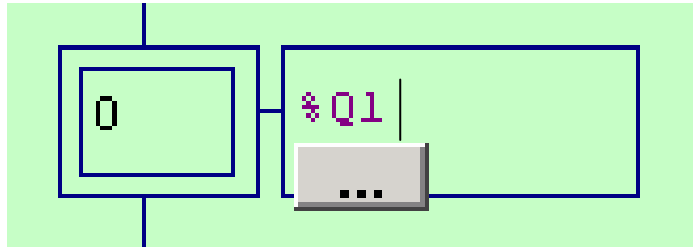
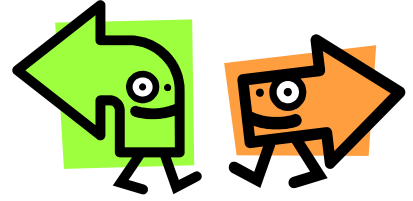



Creating automation application 6/6

www.irai.com

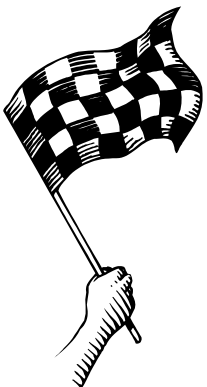
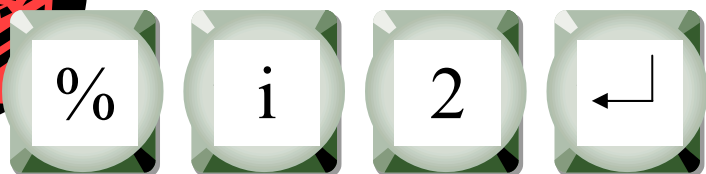
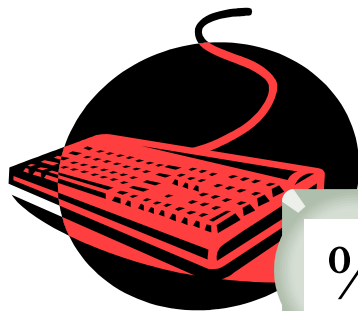
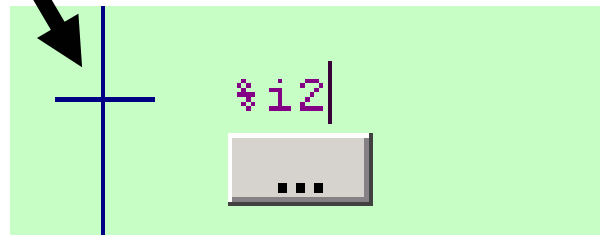
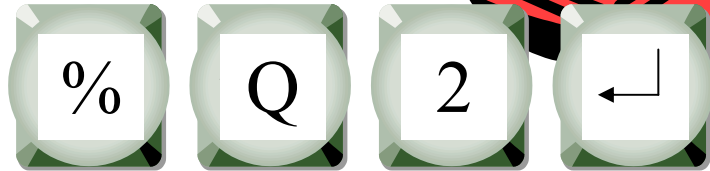
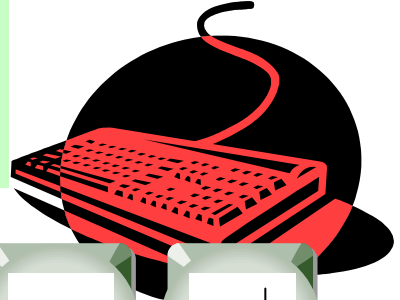
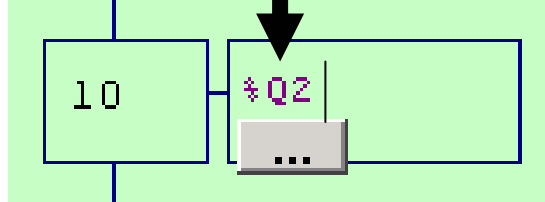
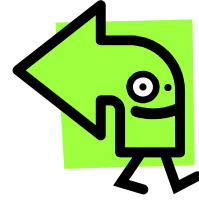

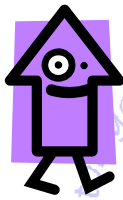

7

www.tra.com

Running an application on a PC



Current	Name	Version
	PC	7.000
	PL7 (Tsx 37 & Ts...	7.003
	PL72	7.000

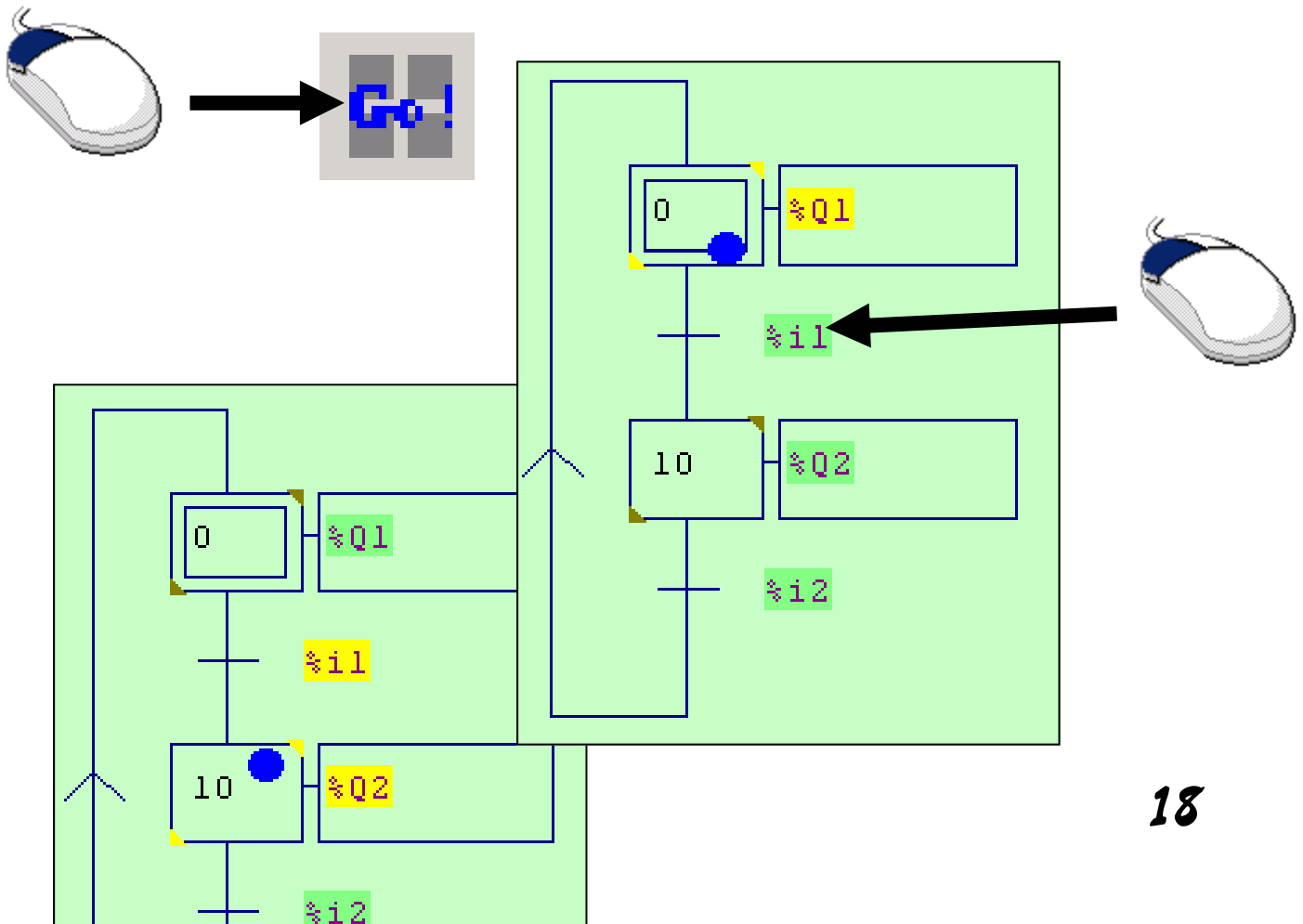



7

www.irai.com

Add a supervision object 1/2

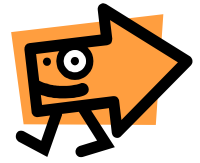

IRAI

Add an IRIS 2D object



- My objects
- Preset objects
- Console elements
 - Recorder
 - Messages
 - Displays
 - Switches
 - Numeric elements
 - Lights
 - Pushbuttons
 - Emergency stop
 - Black round button
 - Red round button
 - Green round button
 - Blue round button
 - Stop, reset
 - Start, set

Paramètres	Valeurs
Action(s) associée(s) à l'état bp appuyé	<input type="text" value="i1=1"/>
Action(s) associée(s) à l'état bp relaché	<input type="text" value="00=0"/>

% i 1 = 1





7

www.traai.com

Add a supervision object 2/2

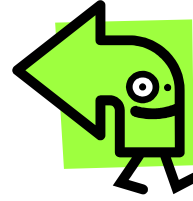

Paramètres	Valeurs
Action(s) associée(s) à l'état bp appuyé	%I1=1
Action(s) associée(s) à l'état bp relaché	<input type="text" value="%I1=0"/>

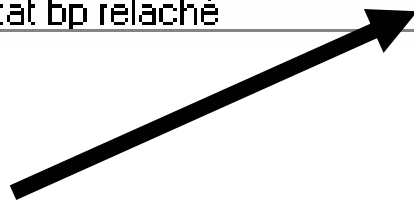

%

i

1

=

0





Running an application on a PLC

www.ira.com

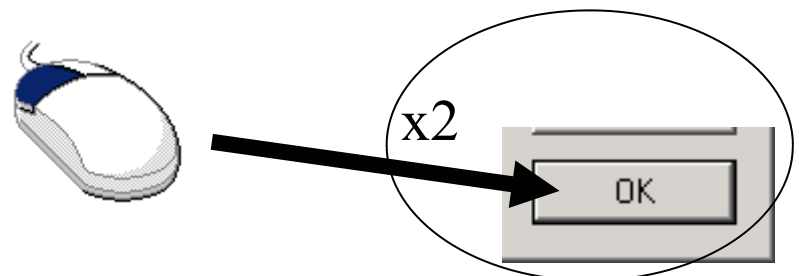
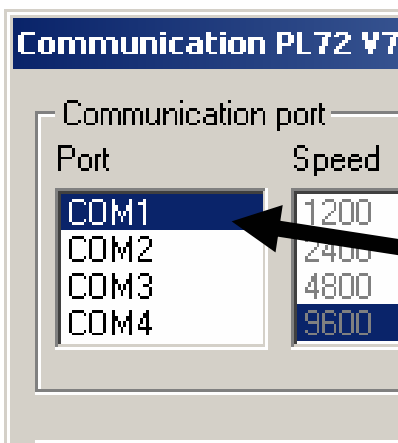
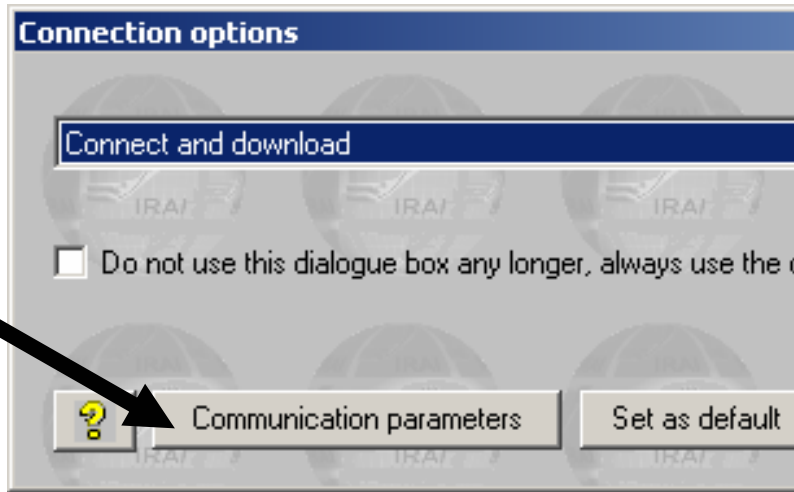
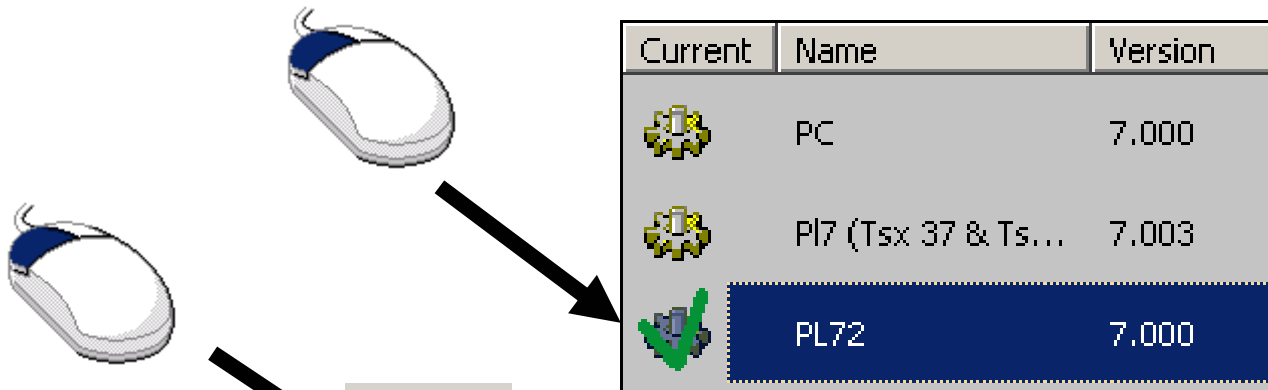
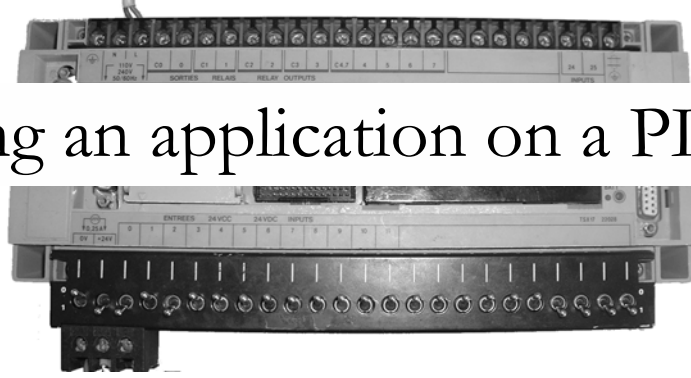

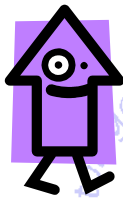

Opening an example of 3D OP simulation

www.irai.com

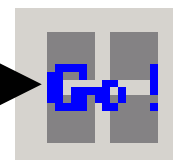
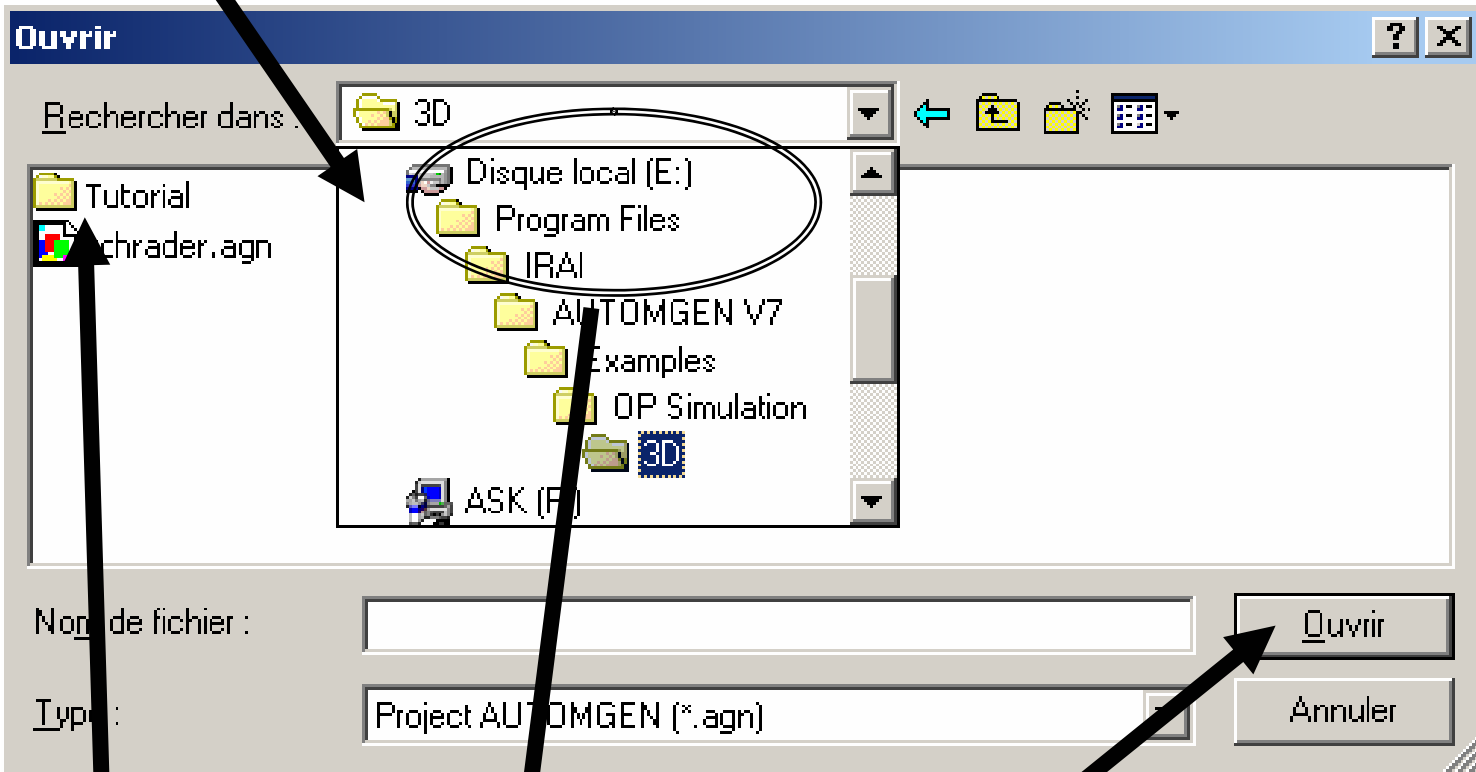
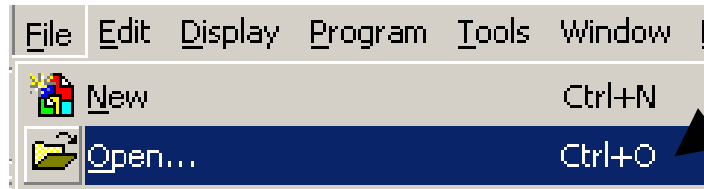



Creating a 3D OP simulation application

www.irai.com

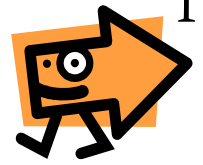

1/8



SOLIDWORKS
SOLIDCONCEPTER



3DSTUDIO
AMAPI3D
<http://delphi3d.free.fr>

CROSSROADS

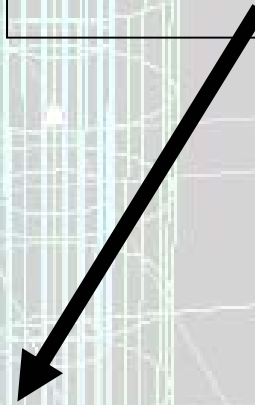
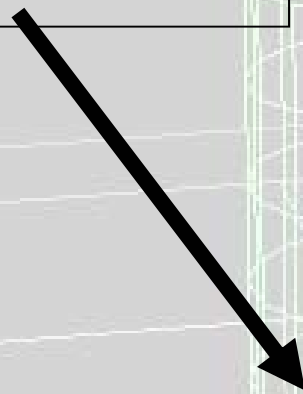

n x  .3DS



A .3DS file for each 3D object must be moved separately

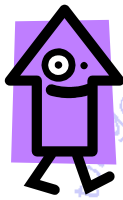

Creating a 3D OP simulation application

www.irai.com

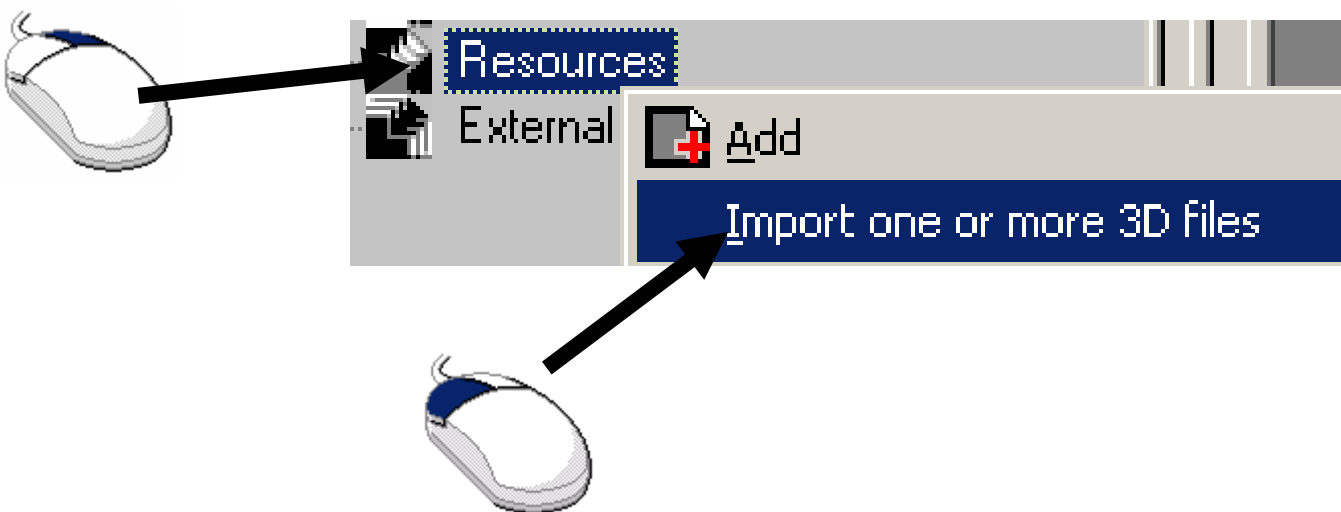
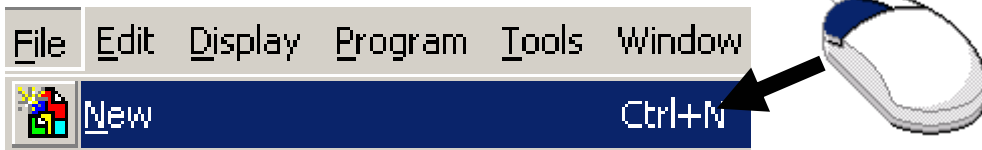
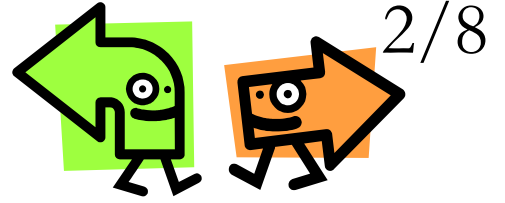

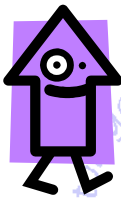

Creating a 3D OP simulation application 3/8

www.irai.com

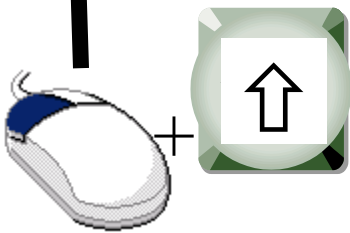
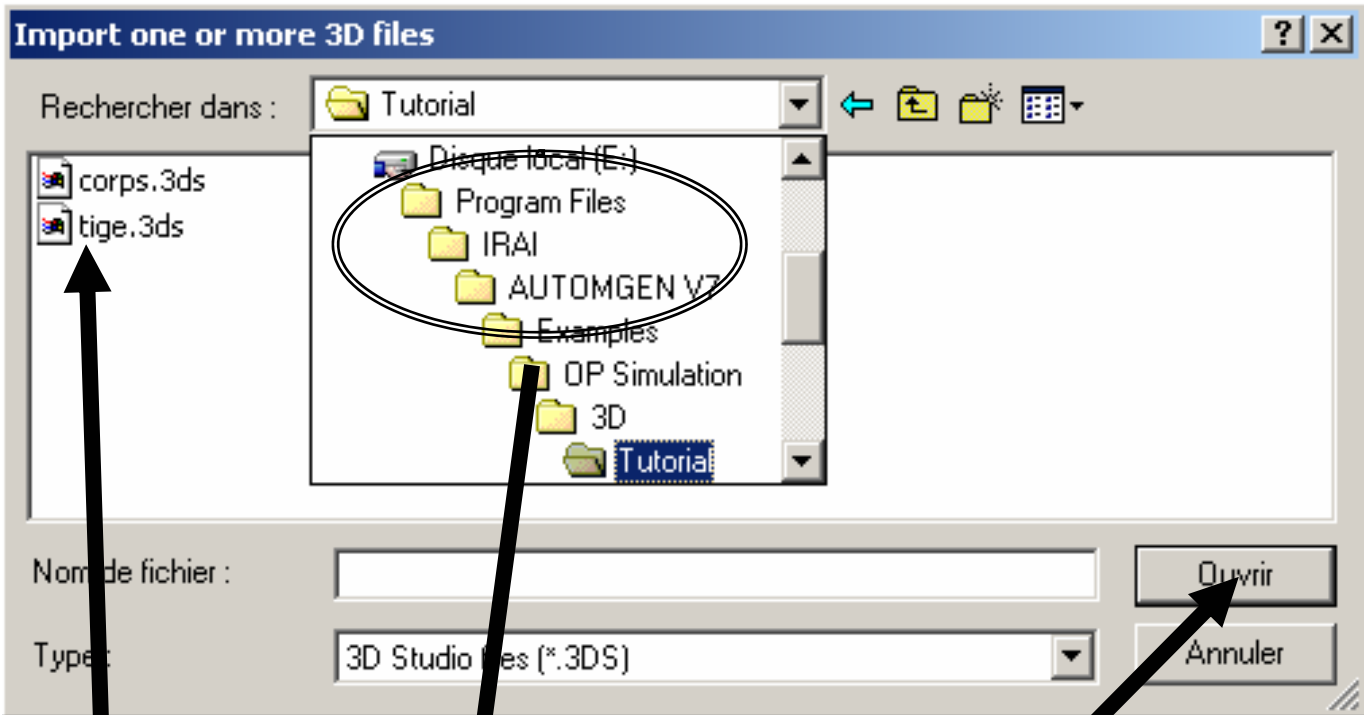
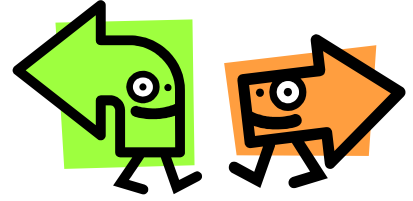

Dossier d'installation

E:\Program Files\IRAI\AUTOMGEN V7

Parcourir...

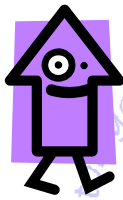

Creating a 3D OP simulation application

www.irai.com

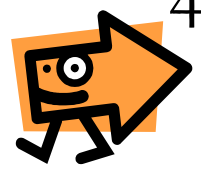
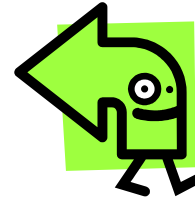

4/8

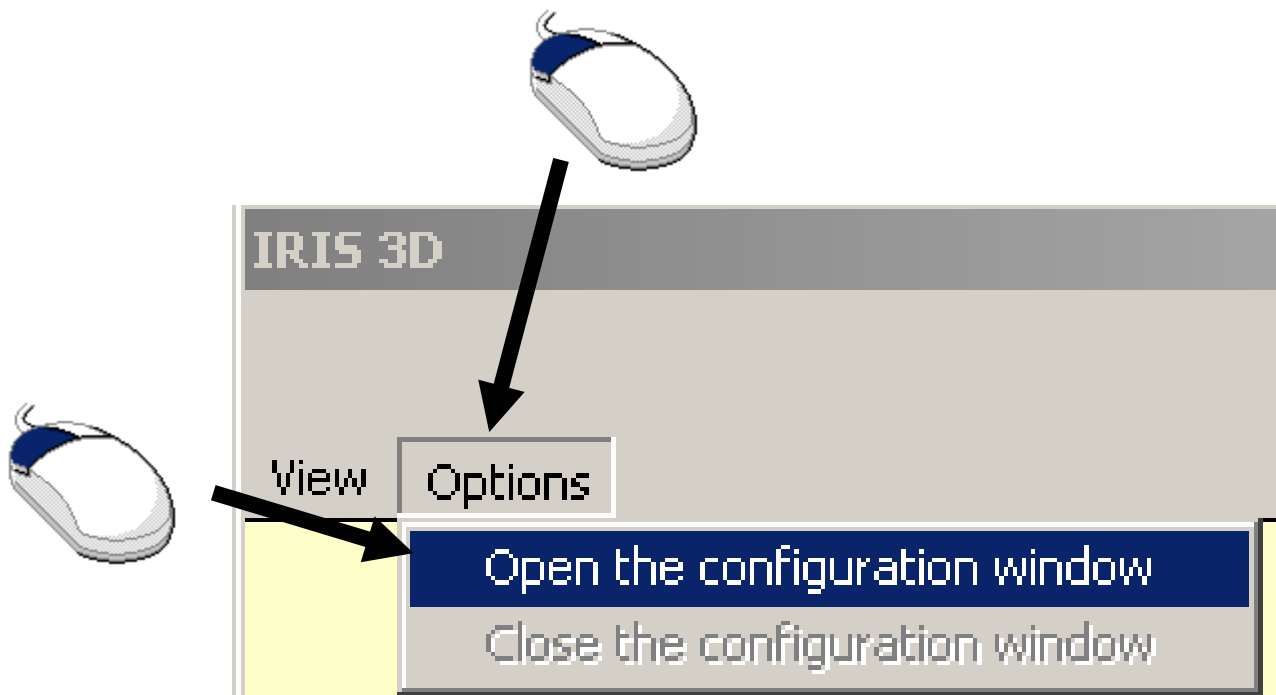
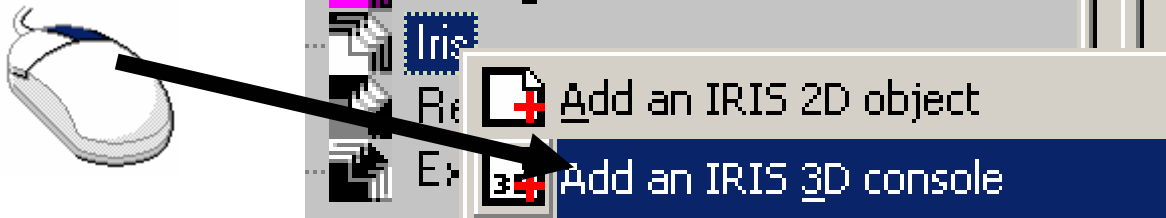



Creating a 3D OP simulation application

www.irai.com

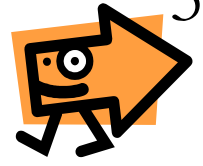

5/8

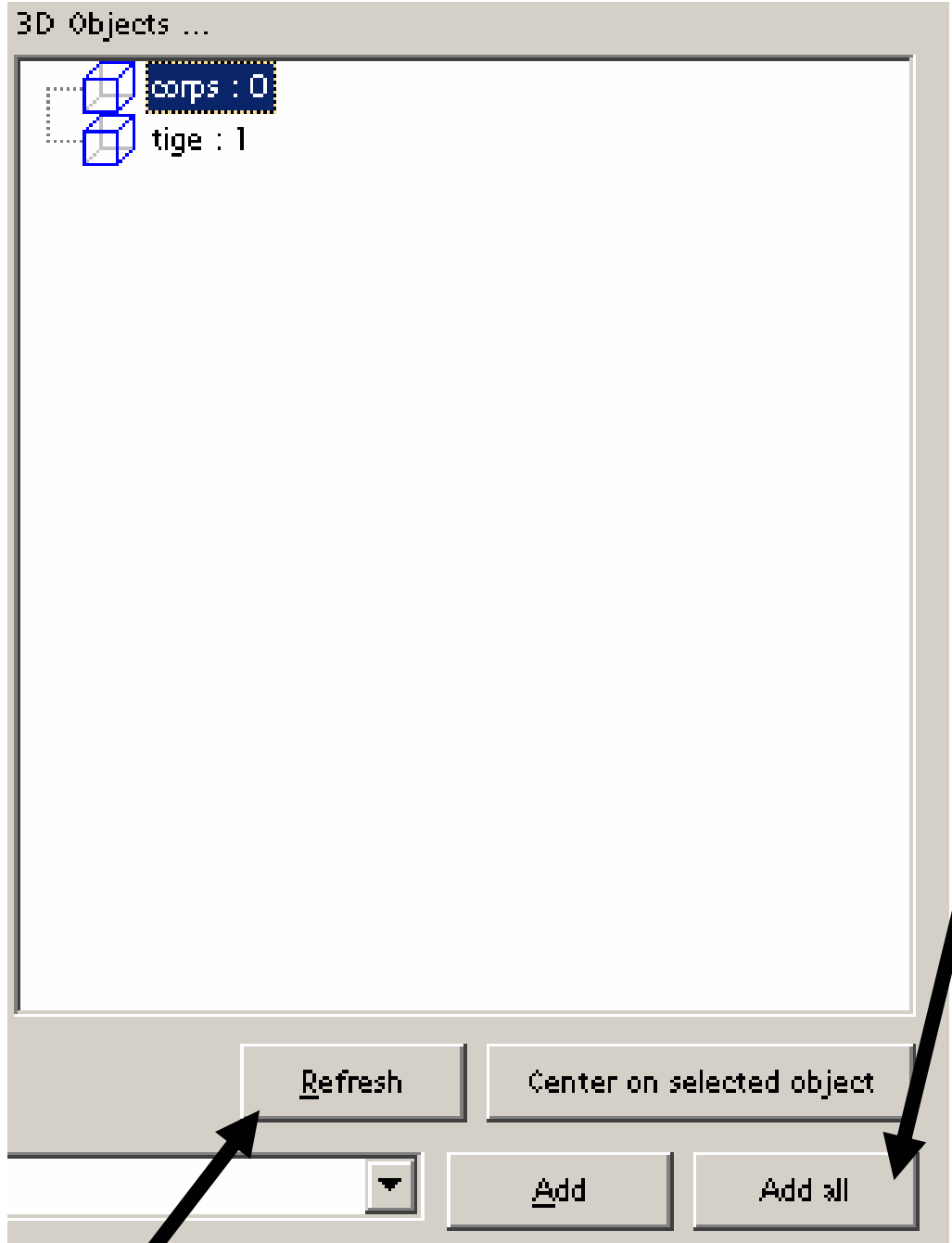

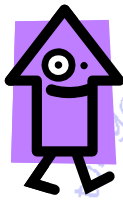

Creating a 3D OP simulation application

www.irai.com

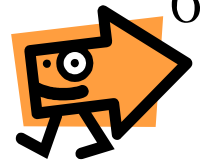
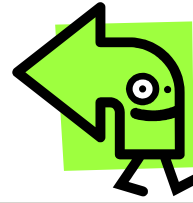

6/8

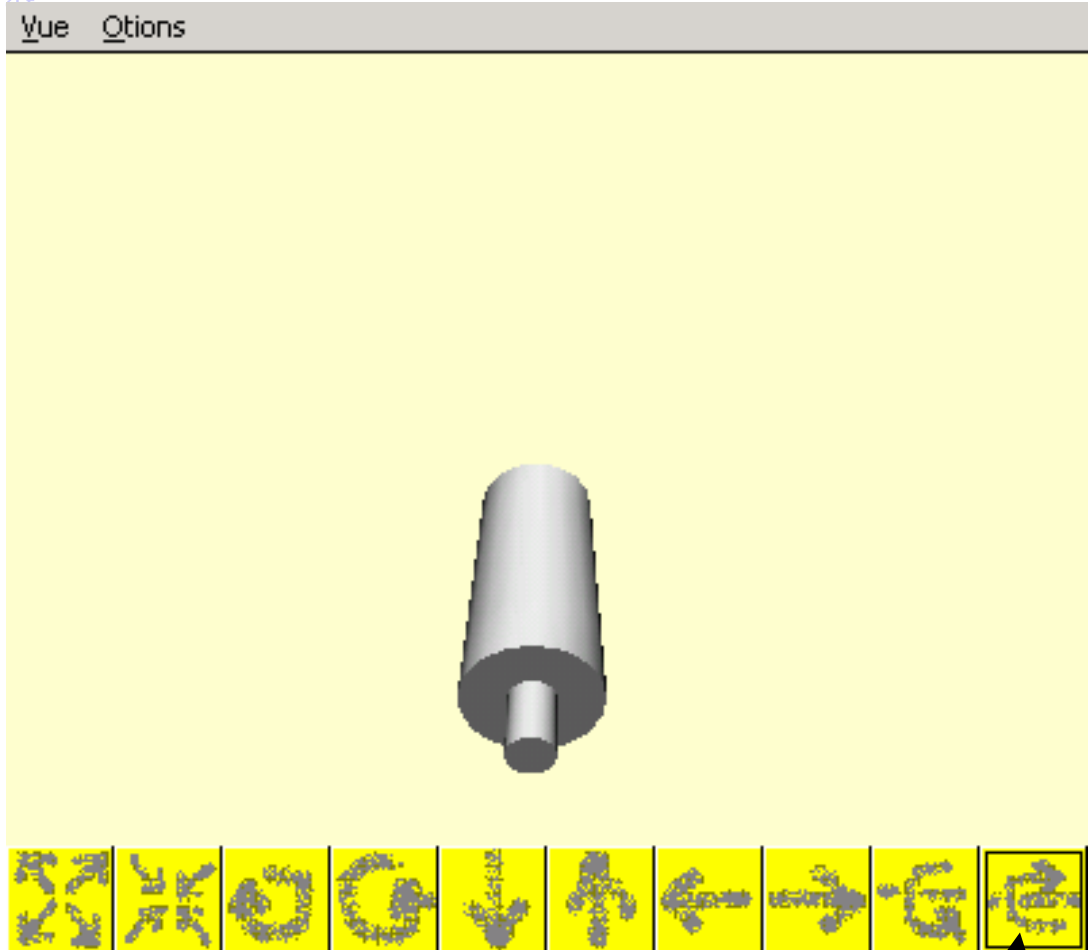

Add a translation

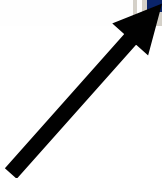

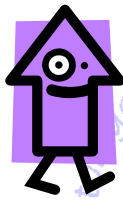

Creating a 3D OP simulation application

www.irai.com

7/8

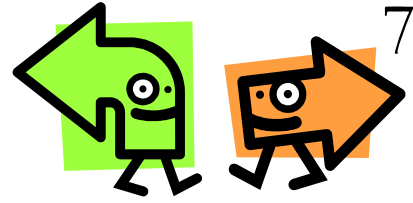

Translation

tige : 1

Position

No piloting

Bistable piloting

Monostable piloting

Numerical piloting

Mini: 0.000000

Maxi: -10

Time to run in ms: 1000

Axis

X

Y

Z

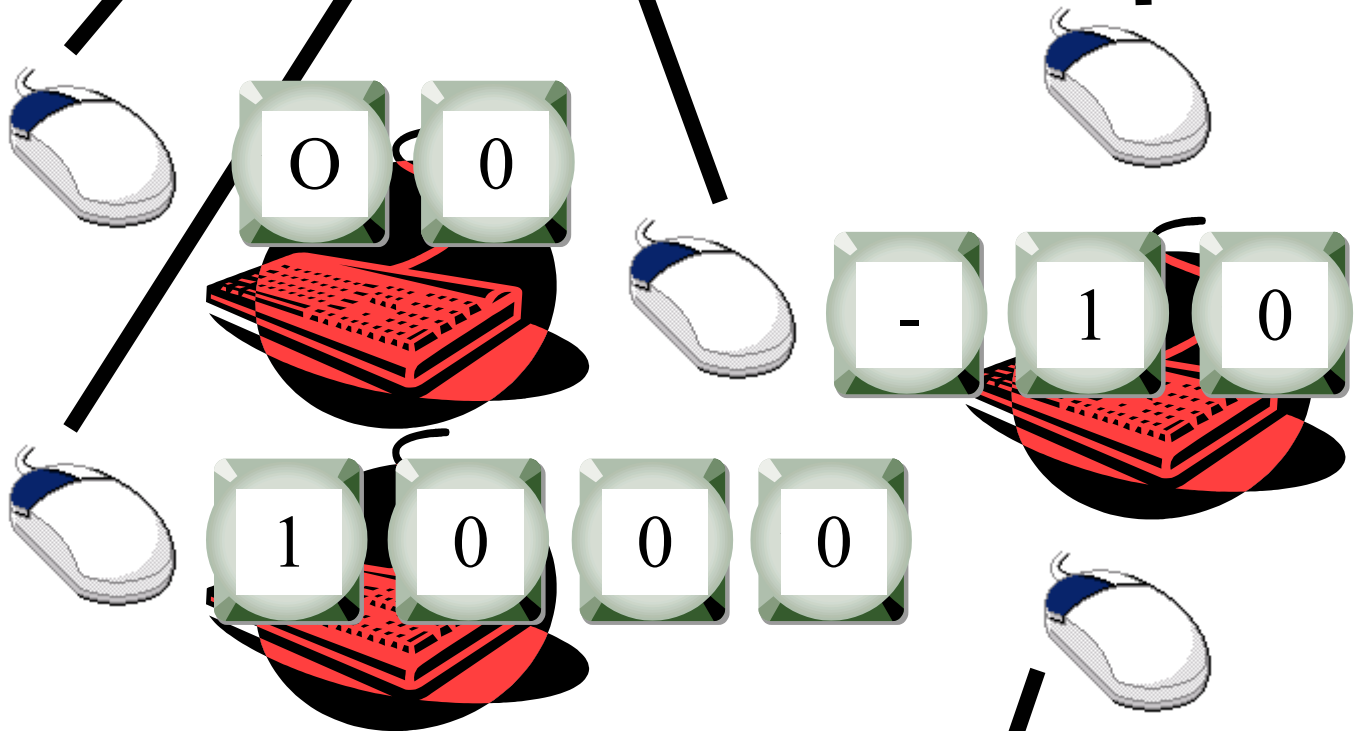

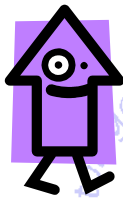

Creating a 3D OP simulation application

8/8

www.ira.com

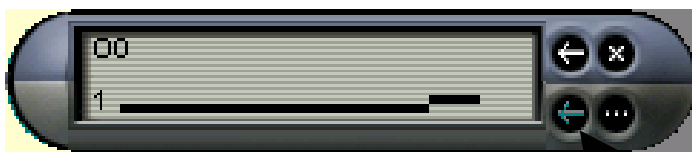
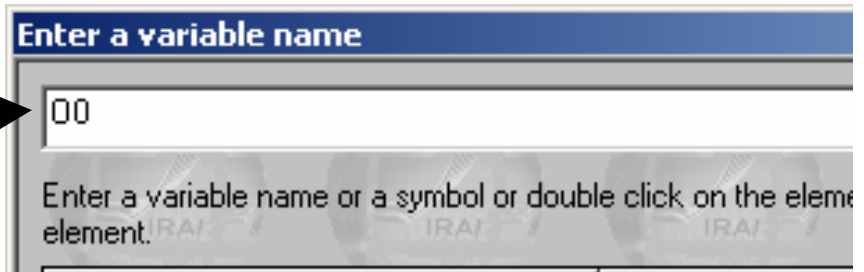
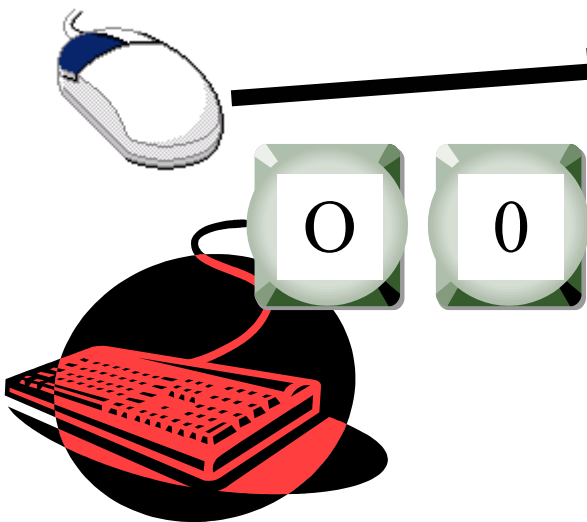
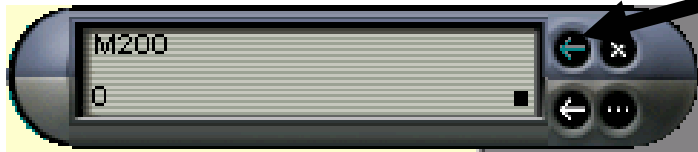
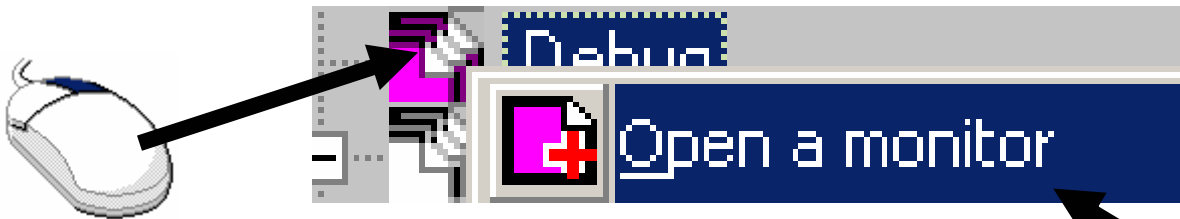
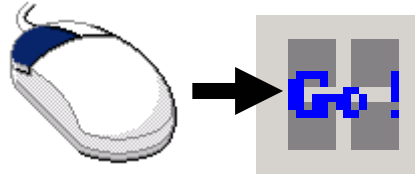
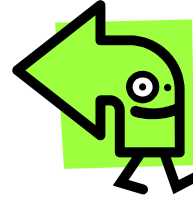

30



7

www.irai.com

To find information

Starting with the software	This manual
To learn more about the language syntax elements	Language reference manual
To learn how to use the environment including IRIS 2D and IRIS 3D objects	Environment reference manual
To learn how to use post-processors	Post-processor reference manual
For additional information	www.irai.com





7

www.iraï.com



Contact IRAI



(33)4 66 54 91 30

(33)4 66 54 91 33

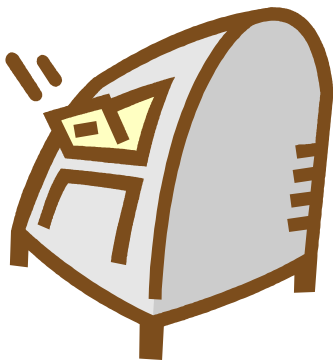

IRAÏ
BP 14
17 avenue du 19 mars 1962
30110 LA GRAND COMBE
FRANCE

contact@iraï.com

