

# ENGINEERING SERVICES

“Fluid flow and heat transfer analyses definitely improve the design process; saving valuable time, resources, and dramatically reducing R&D costs.

This brochure provides information on how your organization can benefit from engineering services related to fluid flow and heat transfer analyses offered by Adaptive Research.”

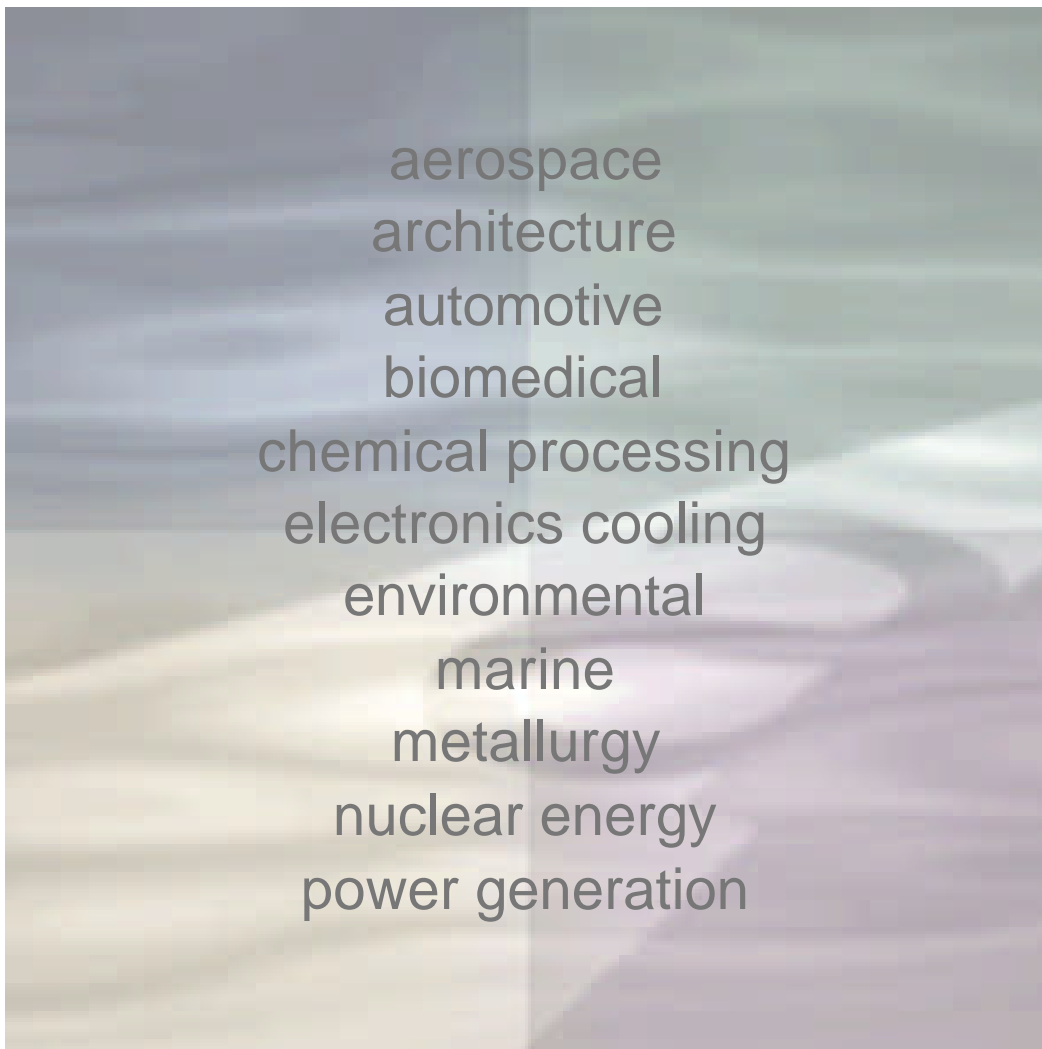

**A D A P T I V E   R E S E A R C H**

---

---

# Engineering Services

## Company Objective

Adaptive Research is dedicated to providing its clients with accurate engineering solutions to fluid flow and heat transfer problems in a timely manner. Adaptive Research offers a full array of consultant services from its broad experience in Computational Fluid Dynamics (CFD) analysis. Engineering contracts range from short-term studies aimed at solving specific flow problems, to full-blown case analyses involving design and optimization variants.

## Engineering Services Group

The team of CFD specialists at Adaptive Research combines experience in modeling a wide range of fluid flow and heat transfer problems for various industries, such as biomedical, environmental and aerospace. The group uses a suite of CFD software tools that effectively model laminar and turbulent flows, compressible and incompressible flows, Newtonian and non-Newtonian flows, as well as problems involving heat and mass transfer, chemical reactions, free surface, particle tracking, radiation, and fluid-structure interaction.

## Engineering Services Programs

Adaptive Research offers a variety of programs to suit every budget and need. Engineering contracts typically fall into one of the following categories:

- Level I – one day to several days
- Level II – one week to several weeks
- Level III – one month to several months

All engineering projects are accurately scoped and well defined before work commences. Project deliverables typically include:

- Detailed project report
- CFD model files and results files
- Analysis / post-processing files and outputs

## CFD Training Seminars

Adaptive Research also offers training seminars for general and advanced CFD topics. General training seminars typically last 2-3 days, and are taught in a dedicated CFD computer lab at Adaptive Research. Advanced CFD seminars last 1-5 days, and are offered both on and off-site. Advanced topics include (but are not limited to):

- CAD/CFD Integration
- Advanced Heat Transfer Analysis
- CFD in Biomedical Applications
- Advanced Chemistry using CFD
- CFD Customization Techniques

## Analysis Presentation Services

With over 10 years of experience in defining, executing, and analyzing CFD simulations, Adaptive Research has developed innovative techniques and products that significantly improve the presentation of CFD engineering solutions. The products offered provide static, dynamic, and interactive capabilities that are both computer CDROM and web-based. Presentation product services offered include:

- Interactive slide shows
- Animation production
- Web-based presentation
- CDROM-based presentation

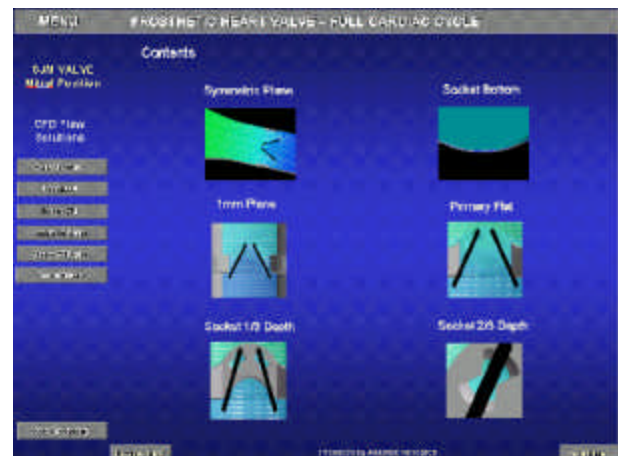

---

---

# Computational Fluid Dynamics

## What Is CFD?

Computational Fluid Dynamics is a powerful engineering tool for simulating all types of fluid flows. CFD simulations produce detailed descriptions of flow characteristics including values for velocities, pressures, and other variables. Thermal characteristics and other advanced physics, like chemical reactions, can also be simulated.

## Why use CFD?

Computational Fluid Dynamics can significantly reduce design and development time, provide detailed information otherwise not available from physical experiments, and quickly simulate a wide range of flow conditions. The results are improved designs, lower risk, and shorter time to market for a product or process.

## How does CFD work?

CFD simulations involve solving numerically the fundamental laws of physics, called governing equations, which mathematically describe the properties and motion of fluids. The CFD modeling process occurs in three fundamental steps.

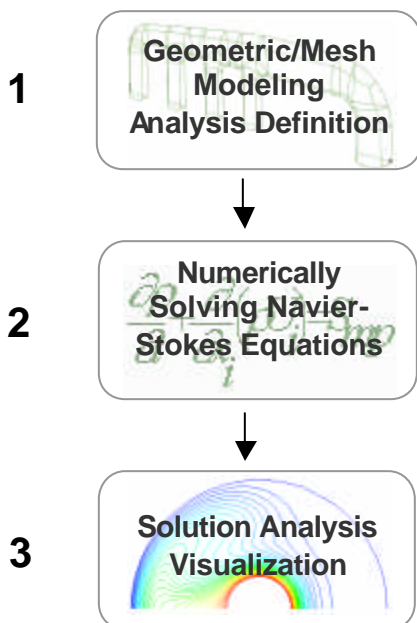

## STORM/CFD2000 Software

Adaptive Research uses STORM/CFD2000 for performing engineering contracting work. STORM/CFD2000 is an integrated program providing the necessary tools for simulating real engineering applications. The system includes modules for geometry creation and grid generation, a Navier-Stokes equation solver, and advanced scientific visualization.

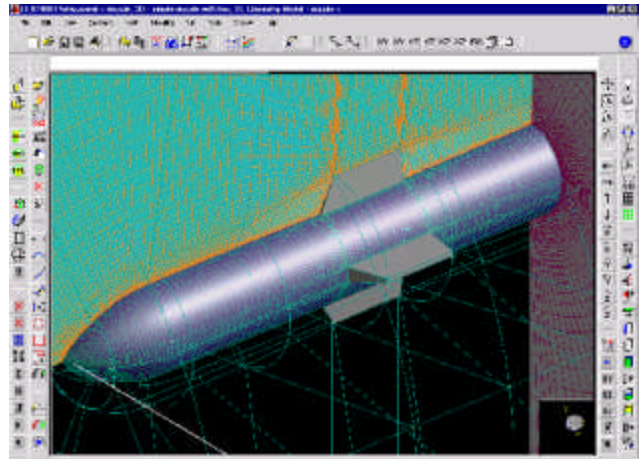

STORM is a 3D viscous flow solver that combines a strongly conservative finite-volume formulation with advanced physical modeling capabilities such as:

- Turbulence · Chemical and surface reactions
- Conjugate and radiative heat transfer
- Porous media · Lagrangian particle tracking
- Free surface · Moving grid
- Fluid-structure interaction

STORM is fast, efficient and has been extensively validated against experimental data. The finite-volume discretization of the conservation equations in general curvilinear coordinates yields accurate results on any smoothly varying grid even in the presence of significant non-orthogonality. By utilizing the integral form of the equations, conservation is enforced exactly and the PISO algorithm (pressure-implicit with splitting operators) produces superior steady-state and transient solutions.

---

# Biomedical Engineering

## Introduction

Computational Fluid Dynamics (CFD) provides a non-invasive tool to perform physiological flow analyses in the cardiovascular system. Possible applications range from simple studies such as arterial bifurcations, aneurysms and stenoses to more complex configurations like prosthetic heart valves, catheters or artificial organs. Whether it is used to predict vascular surgery outcome, arterial disease evolution or medical device performances, CFD techniques can often provide accurate flow information that would not be otherwise available through in vivo or in vitro measurements. In addition, CFD simulations are generally faster and more cost effective than traditional laboratory experiments. Applications of Computational Fluid Dynamics have successfully involved catheter implants, miniature fluid pumps, breathing devices or artificial hearts.

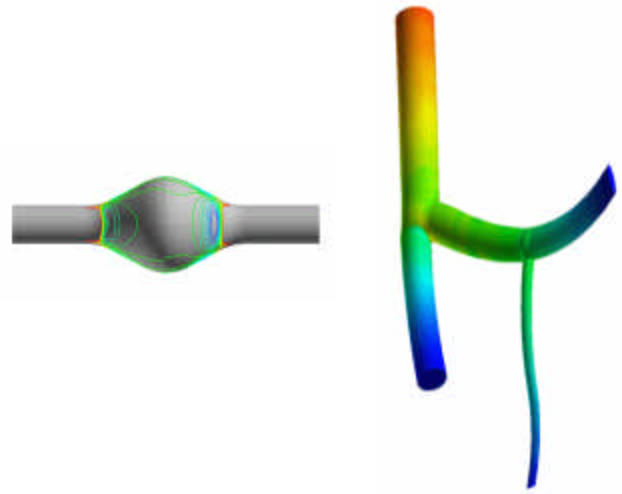

Cardiovascular System

## Design Optimization of Medical Devices

Among the wide range of possible applications in biomedical engineering, Computational Fluid Dynamics can play a significant role in the design and optimization of medical devices. For example, CFD simulations have helped design mechanical heart valves and obtain flow structure data in regions inaccessible experimentally such as the socket area. Similarly, numerical techniques have proved to be crucial for the design of blood cardioplegia devices where both water and blood paths in the heat exchanger could be optimized based on CFD results.

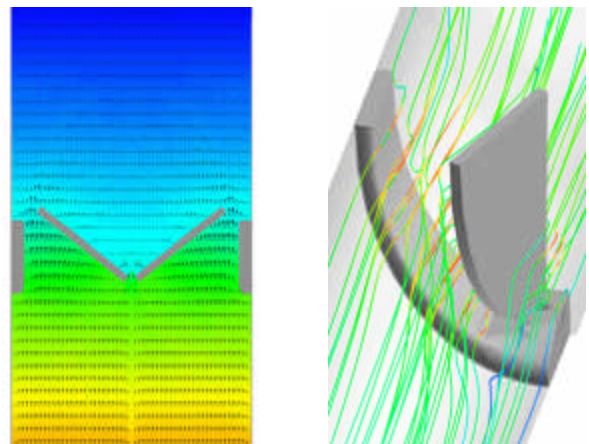

Mechanical Heart Valve

## Example Engineering Applications

The figures at right show typical biomedical applications for which the STORM/CFD2000 package was used to perform detailed flow analysis and design assessment. Accurate knowledge of flow structures, shear rates and pressure distributions is often critical when dealing with the cardiovascular system and implants of medical devices.

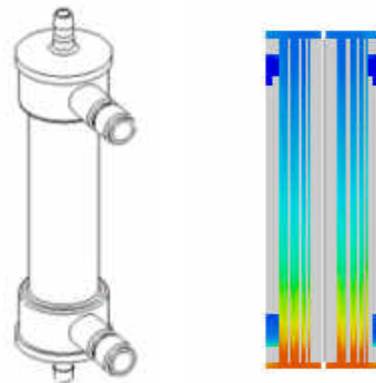

Blood Cardioplegia Device

---

---

# Environmental Engineering

## Introduction

Computational Fluid Dynamics (CFD) provides an efficient tool to perform detailed flow analyses in both air and water environments. Recent accidents have cruelly demonstrated the need for better ventilation and smoke detection systems in case of tunnel fires. Detection of atmospheric and water pollution is also a growing concern in urban settings. Whether it is used to reduce the risk of contamination or to prevent hazardous conditions, CFD techniques can often provide accurate flow information that would help improve safety and protect lives. In addition, CFD analyses are generally faster and more cost effective than traditional experiments and measurements. Applications of Computational Fluid Dynamics have successfully involved nuclear storage unit certification, smoke sensor design, water pollution detection or HVAC systems optimization.

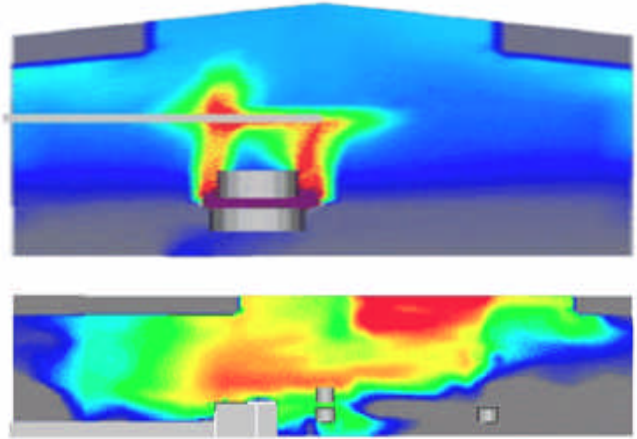

Smoke propagation from Industrial Furnace

## Pollution and Smoke Dispersion

Among the wide range of possible applications in environmental engineering, Computational Fluid Dynamics can play a significant role in the detection of pollutants and smoke from fires. For example, CFD simulations have been used to predict concentration of toxins in urban settings under various topologic and atmospheric conditions. Similarly, numerical techniques have proved to be crucial for the optimization of ventilation systems in buildings or tunnels to guaranty people's safety in case of fire and smoke propagation.

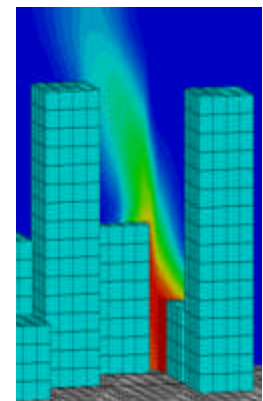
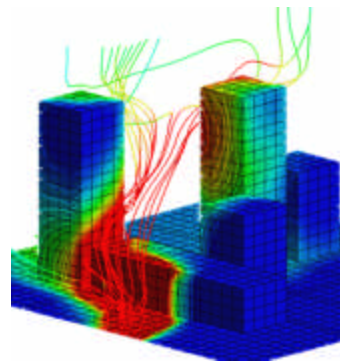

Toxin Dispersion in Urban Settings

## Example Engineering Applications

The figures at right show typical environmental applications for which the STORM/CFD2000 package can be used to perform detailed flow analysis in urban settings or buildings. Accurate knowledge of flow structures and concentrations is often critical when predicting the dispersion of smoke and pollutants in atmospheric or ambient air conditions.

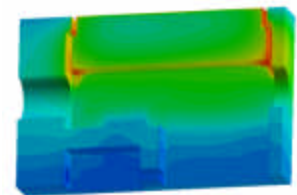
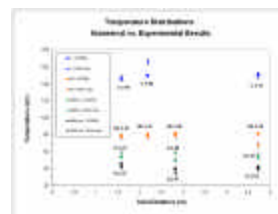
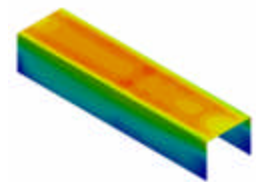
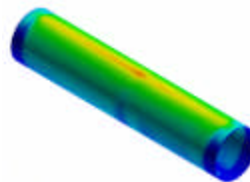

Spent Nuclear Fuel Storage

---

---

## Other Engineering

### Chemically Reacting Flows

The list of engineering applications requiring advanced models to simulate chemically reacting flows is almost endless. They can range from flame propagation to chemical vapor deposition, including engine combustion, catalytic reactions or even hypersonic air dissociation. The figure at right shows the transient solution predicted by STORM/CFD2000 during the cycle of an internal combustion engine. Knowledge of fuel concentration, flame front and temperature distribution is achieved through a combination of advanced reaction and species transport models, as well as Lagrangian particle tracking methods.

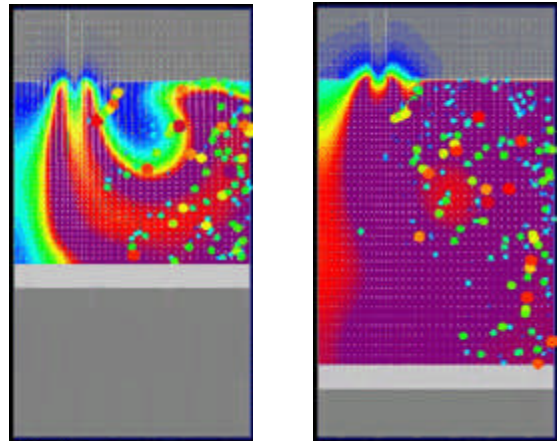

### Electronic Packaging

As the industry tends to put more components into a smaller space, thermal management has become one of the key factors in designing the new generation of computers and many other electronic devices. CFD simulations can help optimize cooling system design, thereby increasing components lifetimes and minimizing the possibility of hardware errors. The figure at right shows a typical engineering cooling application for which the STORM/CFD2000 package was used to perform a detailed thermal analysis of a motherboard including chips, SIMMs and several feature cards.

Internal Combustion Engine

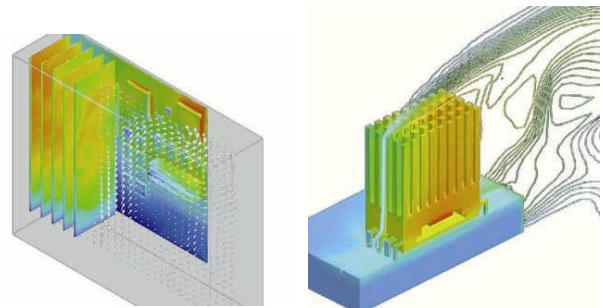

Electronics Cooling

### Aerodynamics

Computational Fluid Dynamic techniques have been long used in the aerospace industry to predict in flight characteristics of military and commercial aircrafts, missiles or space vehicles. CFD simulations can provide critical design information such as lift, drag, and thermal loads. The STORM/CFD2000 package includes advanced capabilities for aerodynamic analysis of bodies in turbulent compressible flows. The figure at right is an generic example showing skin heating characteristics for a missile in supersonic (Mach 3) flight conditions.

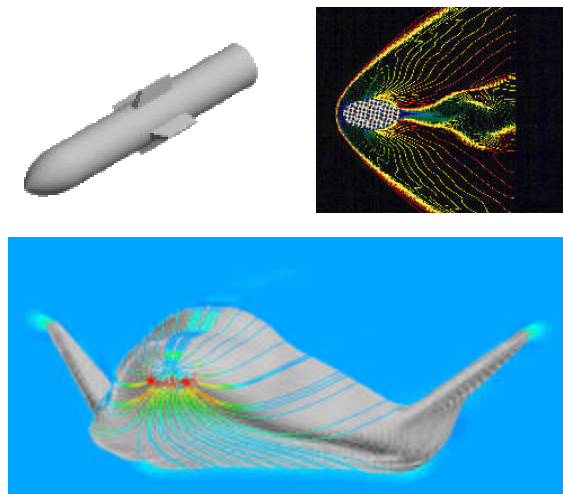

Aerodynamics

---

---

## Company Information

### About Adaptive Research

Adaptive Research, a division of Simunet Corporation, has over 10 years of experience in the development and marketing of advanced CFD software, as well as delivering expert scientific and engineering services to commercial and governmental clients. From the beginning, Adaptive Research has been recognized as a pioneer in the application of numerical analysis to problems involving fluid flow, heat transfer and chemical reactions.

In 1992, Adaptive Research released CFD2000, an advanced 3-D graphical user interface for the specification of CFD model geometries, boundary conditions, fluid properties, solution control parameters and automated grid generation. In 1993, Adaptive Research released STORM, a finite-volume flow solver employing all new technology and programming techniques. STORM replaced and surpassed the antiquated solvers of the past and provided a unique open-architecture for customized CFD modeling. In 1996, Adaptive Research released a totally integrated version of its CFD software suite consisting of CFD2000, STORM and a customized version of Fieldview from Intelligent Light. Development of the integrated CFD software suite has continued to add advanced analysis capabilities such as: finite-rate chemistry, multi-components flows, free surface, radiation, moving body treatment, fluid-structure interaction and CAD data import.

In 1999, Adaptive Research became an operating division of Simunet Corporation, and has continued to provide expert engineering services in a wide variety of complex industrial, environmental and biomedical applications. To learn more about the engineering services or CFD software products offered by Adaptive Research, please call, email, or visit our website at:

[www.adaptive-research.com](http://www.adaptive-research.com)

### Recent Engineering Contract Experience

Work Description	Company
Erosion and Sedimentation	Sandia National Lab
Spent Nuclear Fuel Storage	Southern Cal Edison
Smoke Detector Analysis	First Alert
Unsteady 3D Heart Valve	Medtronic Corporation
Catheter Implant Analysis	Medical Research Group
Implantable Insulin Pump	MiniMed
Cardioplegia Device	Dideco - Sorin Biomedical
Blood Pump Simulation	Abiomed Inc.
Gas Separator Vessel	Perry Equipment Corp

### Recent Publications – STORM/CFD2000

Category	Title
Biomedical	Cardioplegia heat exchanger design modelling using computational fluid dynamics
Dispersion	CFD Analysis of Mine Fire Smoke Spread and Reverse Flow Conditions
Dispersion	Dispersion of an Airborne Toxin in an Urban Area a CFD2000 Case Study
Chemistry	Numerical Study of Chemically Reacting Flows with Catalytic Surface Reactions using the Pressure Correction Algorithm
Chemistry	Numerical Simulation of Chemically Reacting flows by Combining Pressure Correction and Point Implicit method
Automotive	Computational Fluid Dynamics Simulation of the Automotive Spray Painting Process

### Contact Information

Tel: 800-326-5155  
Fax: 626-282-3772  
Email: [sales@adaptive-research.com](mailto:sales@adaptive-research.com)

Adaptive Research  
PO Box 7289  
Alhambra, CA 91801



**[www.adaptive-research.com](http://www.adaptive-research.com)**

**[sales@adaptive-research.com](mailto:sales@adaptive-research.com)**

**(800) 326-5155 ph    (626) 282-3772 fax**